

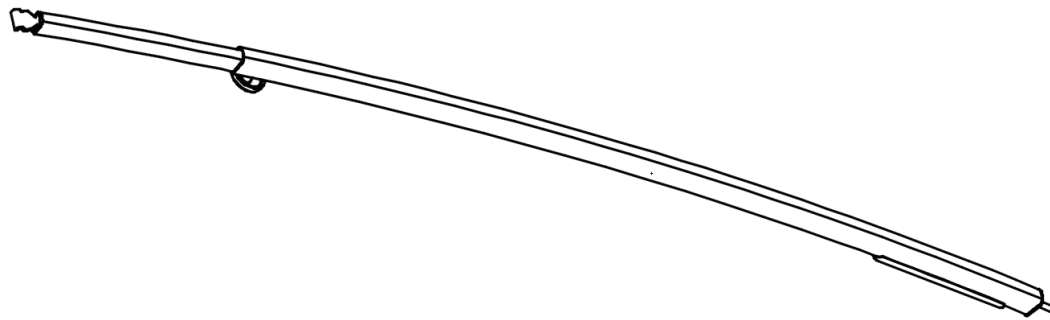

LED CURVED ROOF RAFTER

USER MANUAL



READ CAREFULLY BEFORE USING
KEEP MANUAL FOR FUTURE REFERENCE



Read this installation instruction thoroughly.
Incorrect installation or operation may void any warranty.
Incorrect use or operation may cause serious injury.

PRODUCT INTRODUCTION

Bright white LED lighting brightens up your space while keeping your awning taut and stops water pooling on your awning.

Made to our exclusive design curve and shape, the Aussie Traveller Curved Roof Rafter (CRR) helps to prevent wind flap and sagging in the fabric of the awning and assists water run-off in the rain. The curved design of the Curved Roof Rafter protects against damage and marking to the awning fabric.

FEATURES:

- Bright white LED lights
- No cables - battery powered
- Includes battery charger
- Easy to use & install
- Protects awning fabric
- Available in white & black
- Fitting brackets included
- Suitable for most rollout awnings

PACKING LIST:

- 1 × CRR2 LED
- 1 × Wall Bracket
- 2 × Pan Head Self-Tapping Screw ST4.0x25
- 1 × USB Battery Charger



a.

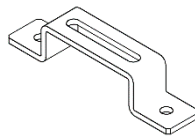

b.

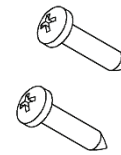

c.



d.

IMPORTANT INFORMATION

1. The CRR2 LED uses 18650 type Li-ion batteries which are not supplied.
2. 18650 batteries are available at most electrical and hardware stores.
3. For your convenience, a battery charger is supplied for easy charging of your rechargeable batteries. Charger indicator light will flash blue when charging. Charger indicator light will be solid blue when charging is complete.
4. USB Battery Charger Specifications:
 - Auto Start / Stop function
 - Features 2 slots independent charging
 - Input: DC5V -3A
 - Output: DC 4.2V 3000mA
 - Certificate: CE FCC ROHS
 - Suitable for 3.7V Li-ion battery
5. CAUTION:
 - Only use rechargeable batteries in this charger.
 - This charger is designed to be used for 18650 type batteries.

1300 663 868 | enquiries@aussietraveller.com.au | aussietraveller.com.au

BRISBANE SHOWROOM: 11-15 Oasis Court, Clontarf QLD 4019 | MELBOURNE SHOWROOM: 235 Barry Road, Campbellfield VIC 3061

PRODUCT INTRODUCTION (cont.)

PARTS

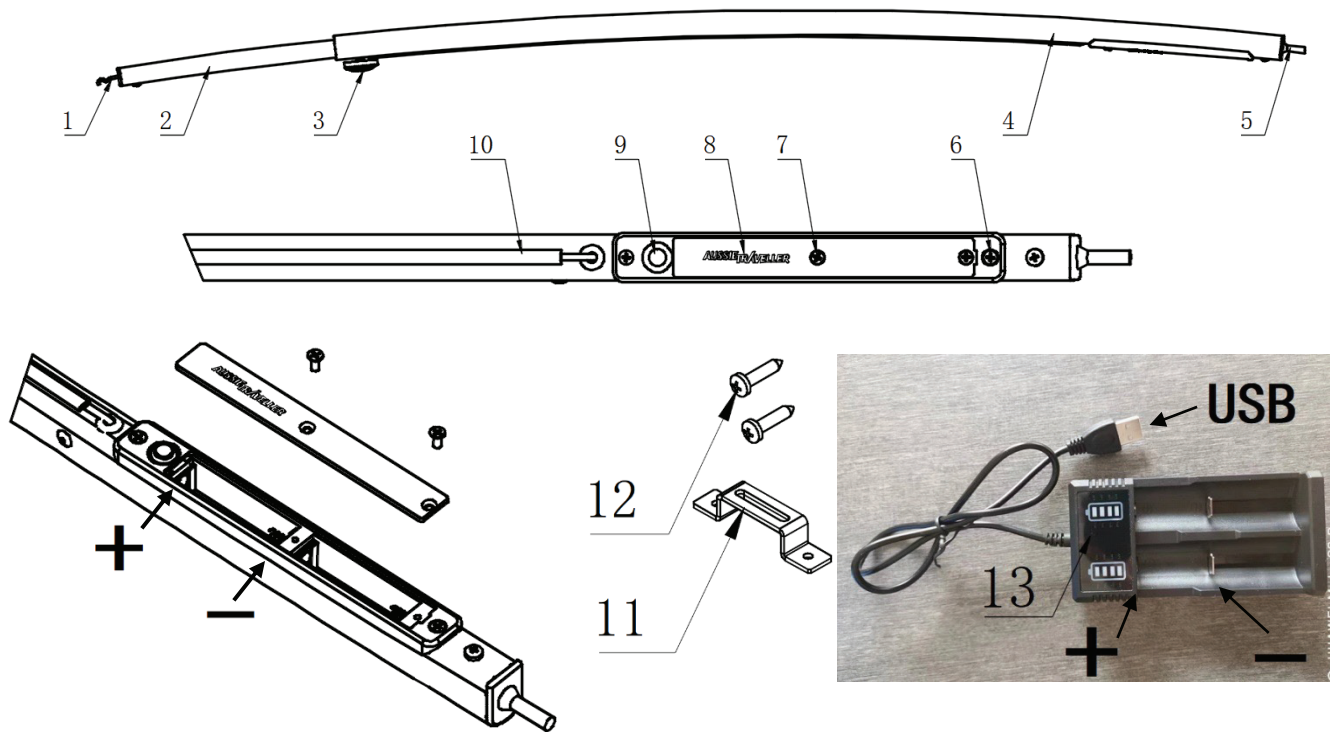

1. Small Hook End
2. Inner Telescopic Tube
3. Knurled Knob
4. Outer Telescopic Tube
5. Spigot End
6. Countersunk Bolt M4x10
7. Countersunk Bolt M4x10
8. Battery Compartment Cover
9. LED Control Switch
10. LED
11. Wall Bracket
12. Pan Head Tapping Screw ST4X25
13. USB Battery Charger

1300 663 868 | enquiries@aussietraveller.com.au | aussietraveller.com.au

BRISBANE SHOWROOM: 11-15 Oasis Court, Clontarf QLD 4019 | MELBOURNE SHOWROOM: 235 Barry Road, Campbellfield VIC 3061

INSTALLATION

1. Ensure you have the recommended number of rafters based on your awning size. Refer to specifications on the Aussie Traveller website.
aussietraveller.com.au/products/curved-roof-rafter-crr
2. Install the wall bracket at the installation position: The centre of wall bracket is 20-25mm down from under side of fabric.

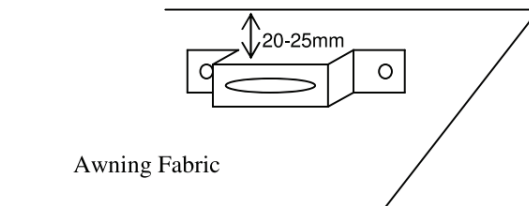

3. Drill a 10mm hole in the roller corresponding to the position of the wall bracket: The hole should sit 20mm down from under side of fabric.

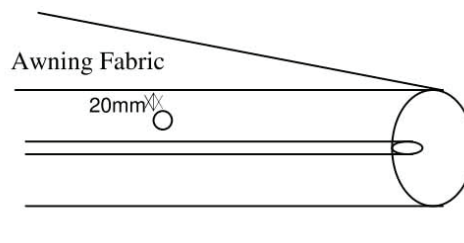

4. Installing the battery:
 - a. Remove the bolts fixed on the battery compartment cover.
 - b. Remove the battery compartment cover.
 - c. To install the battery correctly, the + pole must be in line with the compartment + .
 - d. Before installing a battery, check the positive and negative battery terminals.
 - e. After checking the installation, press the LED Control Switch to test the LED.
 - f. Install the battery compartment cover.

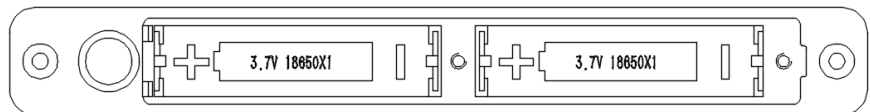
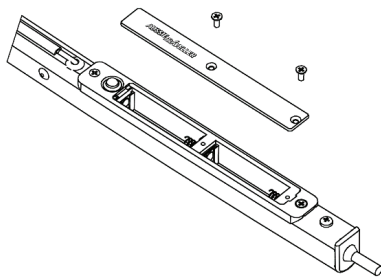

1300 663 868 | enquiries@aussietraveller.com.au | aussietraveller.com.au

BRISBANE SHOWROOM: 11-15 Oasis Court, Clontarf QLD 4019 | MELBOURNE SHOWROOM: 235 Barry Road, Campbellfield VIC 3061

INSTALLATION (cont.)

5. Fit small hook end with wall bracket.

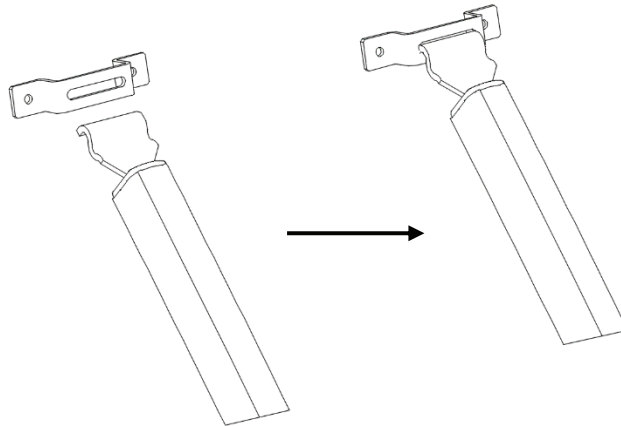

6. Loosen knurled knob.

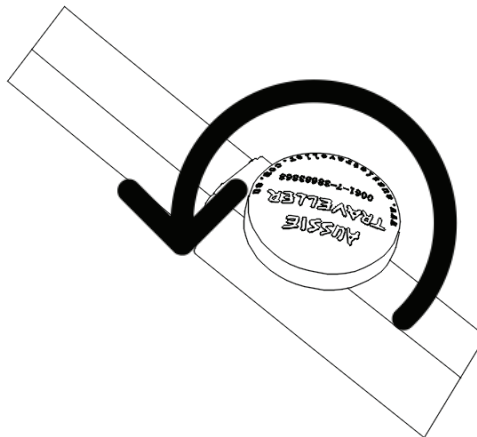

7. Extend out inner telescopic tube and fit spigot into hole in roller.
8. Lock the knurled knob.



1300 663 868 | enquiries@aussietraveller.com.au | aussietraveller.com.au

BRISBANE SHOWROOM: 11-15 Oasis Court, Clontarf QLD 4019 | MELBOURNE SHOWROOM: 235 Barry Road, Campbellfield VIC 3061

TROUBLESHOOTING

PROBLEM		POSSIBLE CAUSE	SOLUTION
In Use	When pressing the LED control switch, the LED does not turn on.	Battery not installed	Install battery
		Battery installation error	Install the battery correctly according to instructions
		Dead battery	Charge and replace the battery

SAFETY PRECAUTIONS:

To reduce the risk of electric shock/injury/fire/death and property damage, be sure to follow the following safety precautions.

Do not attempt to open or service this products electrical components.

⚠ WARNING

- When charging, do not exceed the rated value of the power supply.
 - If too many plugs are connected to a power supply and it exceeds its rating, it may cause a fire due to overheating.
- Make sure that the operating voltage of the power supply connected to the charging cable is consistent with its rated voltage. Please insert Type-A plug fully.
 - Otherwise, electric shock or fire may occur.
- After removing the rechargeable battery, do not keep it within reach of children and infants.
 - Ingesting a battery may cause personal injury, if this happens, seek medical attention immediately.
- This product contains removable rechargeable batteries. Do not put them in fire or heat them. Do not charge, use or store at high temperatures
 - Otherwise, overheating, fire, or explosion may occur.

1300 663 868 | enquiries@aussietraveller.com.au | aussietraveller.com.au

BRISBANE SHOWROOM: 11-15 Oasis Court, Clontarf QLD 4019 | MELBOURNE SHOWROOM: 235 Barry Road, Campbellfield VIC 3061

WARRANTY STATEMENT

Aussie Traveller Pty Ltd ACN 642 775 460 (**Aussie Traveller**) offers the following warranty in relation to the products it supplies directly or through an authorised manufacturer, dealer or approved service repair agent (**Product**).

Australian Consumer Law

The benefits of this warranty are in addition to any rights and remedies imposed by Australian State and Federal legislation that cannot be excluded. Nothing in this warranty is to be interpreted as excluding, restricting or modifying any State or Federal legislation applicable to the supply of goods and services which cannot be excluded, restricted or modified.

If you are a consumer as defined in the Australian Consumer Law: *Our goods come with guarantees that cannot be excluded under the Australian Consumer Law. You are entitled to a replacement or refund for a major failure and compensation for any other reasonably foreseeable loss or damage. You are also entitled to have the goods repaired or replaced if the goods fail to be of acceptable quality and the failure does not amount to a major failure.*

Warranty

Aussie Traveller warrants that, subject to the exclusions and limitations below, all parts of the manufacture and assembly of the Product will be free from defects in materials and workmanship (**Warranty**) for a period of 12 months from the date of purchase as follows:

1. This Warranty is activated at the time of purchase by the final retail customer (being the owner of the Product).
2. In the event the Product is purchased by a manufacturer, dealer or approved service repair agent, this Warranty will commence at the time the final retail customer makes payment for the Product to the wholesale purchaser.
3. If the Product is purchased directly from Aussie Traveller for use by final retail customer and not to be on sold in any way, the Warranty will commence at the time of the original purchase.

Warranty Period

This Warranty cannot be assigned or transferred to a subsequent owner of the Product.

The purchaser or final retail customer should inspect the Product immediately when received or at vehicle handover, to ensure that it appears free from any damage or defect, and matches the description provided.

If after accepting the Product, a defect appears in the manufacture or assembly of the Product before the end of the Warranty Period and Aussie Traveller finds the Product to be defective in materials or workmanship, Aussie Traveller will, in its sole discretion, either:

- a. replace, repair or refund the Product or the defective part of the Product free of charge; or
- b. cause the Product or the defective part of the Product to be replaced or repaired by a qualified repairer free of charge.

In arranging Warranty inspection, service and repair, Aussie Traveller will seek to provide the details of an approved service agent within your geographic area. Should one not be available, or if the Product is in use in travel, Aussie Traveller reserves the right to seek to arrange a repair or replacement at the next available location on the route of travel.

Aussie Traveller reserves the right to replace defective parts of the Product with parts and components of similar quality, grade and composition where an identical part or component is not available.

Products presented for repair may be replaced by refurbished goods of the same type rather than being repaired. Refurbished parts may be used to repair the Product.

Aussie Traveller Awning Products

This Warranty covers specified defects in materials or workmanship for Awning Products as follows:

1. The vinyl fabric is warranted against:
 - a. holes caused by mildew (mildew will form on dust and dirt and stain fabric if fabric is not kept clean).
 - b. excessive cracking, peeling, hardening or loss of strength while used under normal conditions.
 - c. excessive fading (a slight colour change may occur due to ultraviolet rays).
2. All hardware components including the roller are warranted not to bend or break under normal use (excluding high winds, water pooling and accidents).

Making a Warranty Claim

If a defect covered by this Warranty appears, the Customer must first contact Aussie Traveller within 7 days of first becoming aware of the defect. Aussie Traveller will assist the Customer to rectify and resolve any Product issue that may arise.

When making a claim under this Warranty, Aussie Traveller requires that the following information be provided before any further action will be taken.

1. Original Invoice (Document or Number);
2. Make and model of the Product;
3. Make and model of the vehicle (if Product fitted);
4. Vehicle build date (if Product fitted);
5. Vehicle chassis number;
6. Description of damage and/or repair required;
7. Photos of the damage and/or repair; and
8. Appropriate documentation (such as historical and maintenance records).

Aussie Traveller reserves the right to request more information or images should what is provided not be sufficient to make an assessment for the Warranty claim.

The Product must be made available to Aussie Traveller or its authorised repair agent for inspection and testing. If such inspection and testing find no defect in the Product, the final retail customer must pay Aussie Traveller's usual costs of service work and testing.

The final retail customer must bear the cost of the transport of the Product to and from Aussie Traveller or the authorised repair agent, and all insurance of the Product.

Exclusions

This Warranty will not apply where:

- the Product has been repaired, altered or modified by someone other than Aussie Traveller, or without the written consent of Aussie Traveller or an authorised repair agent;
- the alleged defect in the Product is within acceptable industry tolerances and variances;
- Aussie Traveller cannot establish any fault in the Product after testing and inspection;
- the Product has been used other than for the purpose for which it was designed;
- the alleged defect in the Product has arisen due to the final retail customer's failure to properly use and maintain the Product in accordance with any of Aussie Traveller's instructions, recommendations and specifications (including applicable maintenance schedules);
- the alleged defect in the Product has arisen due to the final retail customer's request to customise the Product;
- the Product has been subject to abnormal conditions, including environment, temperature, high or excessive wind, water, fire, humidity, pressure, stress or similar;
- the alleged defect has arisen due to abuse, misuse, neglect or accident;
- unauthorised parts or accessories have been used on or in relation to the Product;
- the Product has been overloaded or involved in an accident;
- the alleged damage or defect has been caused by normal wear and tear;
- the alleged damage to fabric has been caused by storm, wind or rain, or stretching of fabric caused by water pooling on fabric;
- breakage or bending of hardware components has been caused by storm, wind or rain, or water pooling on fabric.

Replacement Warranty Item

If, under Warranty, a Product is replaced or repaired by Aussie Traveller or an Aussie Traveller agent, unless provided in writing to indicate otherwise, the replacement Product will carry the **remaining** Warranty terms and conditions, including length of time, of the original purchased Product.

Change of Mind

Aussie Traveller understands that at times, final retail customers may change their mind. Choose carefully as return and credit requests for items purchased by mistake or "change of mind" reasons may not be approved. Aussie Traveller will not accept Product returns under these circumstances unless by written approval by an authorized Aussie Traveller representative. If approved, an administration and restocking fee may apply.

Limitations

Aussie Traveller makes no express warranties or representations other than set out in this Warranty.

The repair or replacement of the Product or part of the Product is the absolute limit of Aussie Traveller's liability under this express Warranty.

Contact

Australia Wide: 1300 663 868

Melbourne Office

235 Barry Road
Campbellfield, Melbourne, 3061
Ph: +61 3 9357 6565
enquiries@aussietraveller.com.au

Brisbane Head Office, Factory & Showroom

11-15 Oasis Court
Clontarf, Brisbane, 4019
Ph: +61 7 3284 3284
enquiries@aussietraveller.com.au

To receive a copy of the Aussie Traveller Warranty Terms & Conditions or information regarding specific Aussie Traveller products, please contact Aussie Traveller Head Office on (07) 3284 3284 or email enquiries@aussietraveller.com.au.