

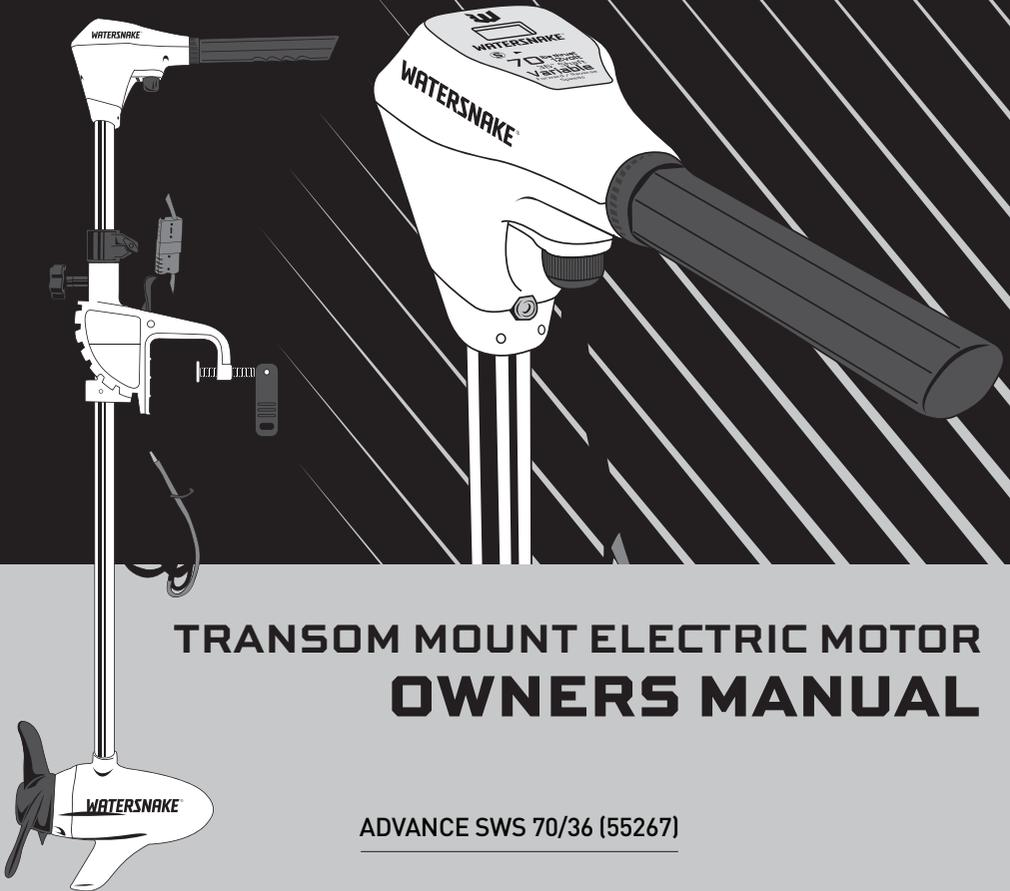

WATERSNAKE[®]

ADVANCE BRUSHLESS



TRANSOM MOUNT ELECTRIC MOTOR OWNERS MANUAL

ADVANCE SWS 70/36 (55267)



BEFORE YOU BEGIN:

Trolling motors are high-current devices that require an ideal power supply. Follow these steps to avoid problems:

1

12V DEEP CYCLE OR 12V LIFEPO4 BATTERIES ONLY

MORE INFO ON PAGE 7

2

**BATTERY CAN BE
CHARGED WHILE USING THE
MOTOR ONLY IF VOLTAGE
INPUT TO THE MOTOR IS
EQUAL OR LESS THAN 14.5V
MORE INFO ON PAGE 9**

3

EXTENDING THE BATTERY CABLES?

IMPORTANT INFO ON PAGE 8

4

SUGGESTED BATTERY SIZE:

MOTOR SIZE	BATTERY SIZE
18LB - 24LB	40AH OR LARGER
34LB	60AH OR LARGER
44LB	80AH OR LARGER
54LB - 70LB	100AH OR LARGER

WELCOME TO WATERSNAKE

Congratulations and welcome to a world of silent motoring.

Powerful yet silent, the Watersnake electric motors are built to suit all angling conditions. High quality materials, superior design and precision engineering make these motors long-wearing and reliable.

IMPORTANT

Please read this manual completely before starting installation and using the electric motor.

Disclaimer: The information provided in this Watersnake Motor Manual is correct at time of printing. For the most up to date information, check for the latest version on our website at <https://www.watersnake.com.au/pages/watersnake-user-manuals>

TABLE OF CONTENTS

KNOW YOUR BOAT.....	4
FEATURES OF YOUR MOTOR.....	5

INSTALLATION

PRE INSTALLATION CHECKLIST.....	6
BATTERY AND POWER.....	7
Best practices and battery type.....	7
Extending battery leads.....	8
Battery charging.....	9
Connecting your motor to the battery.....	10
ATTACHING THE PROPELLER.....	11
ATTACHING THE MOTOR TO YOUR BOAT.....	12

USING THE MOTOR

PRE USE CHECKLIST.....	12
DEPLOYING YOUR MOTOR.....	13
ADJUSTING THE ANGLE OF YOUR MOTOR.....	14
DEPTH ADJUSTMENT.....	14
STEERING COUNTER-FORCE.....	15
HEAD UNIT AND SPEED CONTROL.....	16
STOWING YOUR MOTOR.....	17
RECOMMENDATIONS WHEN USING YOUR MOTOR.....	18
AFTER EVERY USE.....	18
MOTOR MAINTENANCE AND STORAGE.....	19
TROUBLESHOOTING.....	20
OPTIONAL ACCESSORIES.....	21
MOTOR SPECIFICATIONS.....	22
MOTOR SCHEMATICS AND PARTS LISTS.....	23

KNOW YOUR BOAT

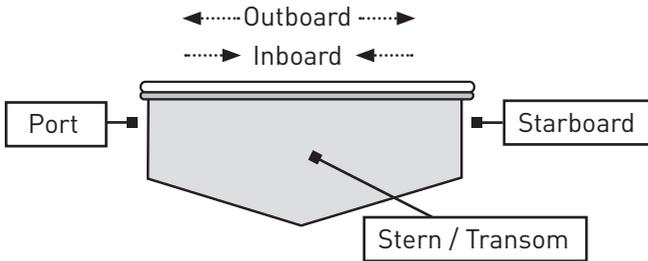
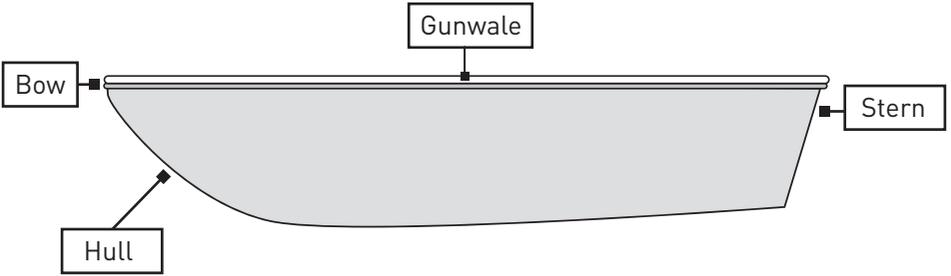
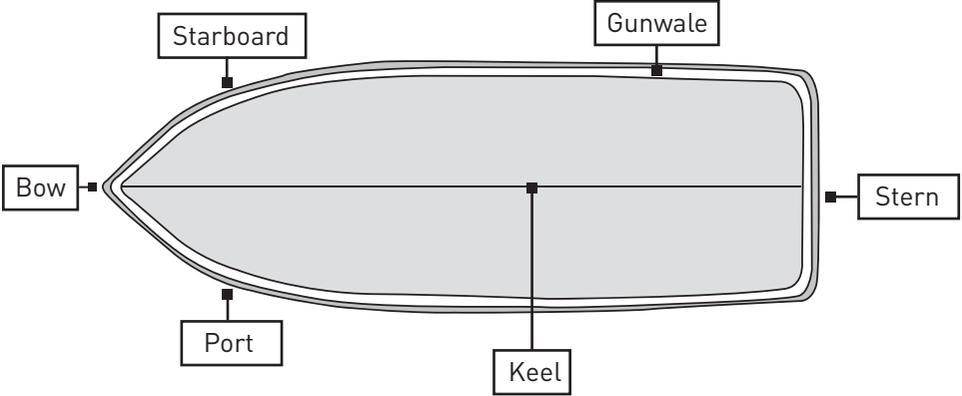

FEATURES OF YOUR MOTOR

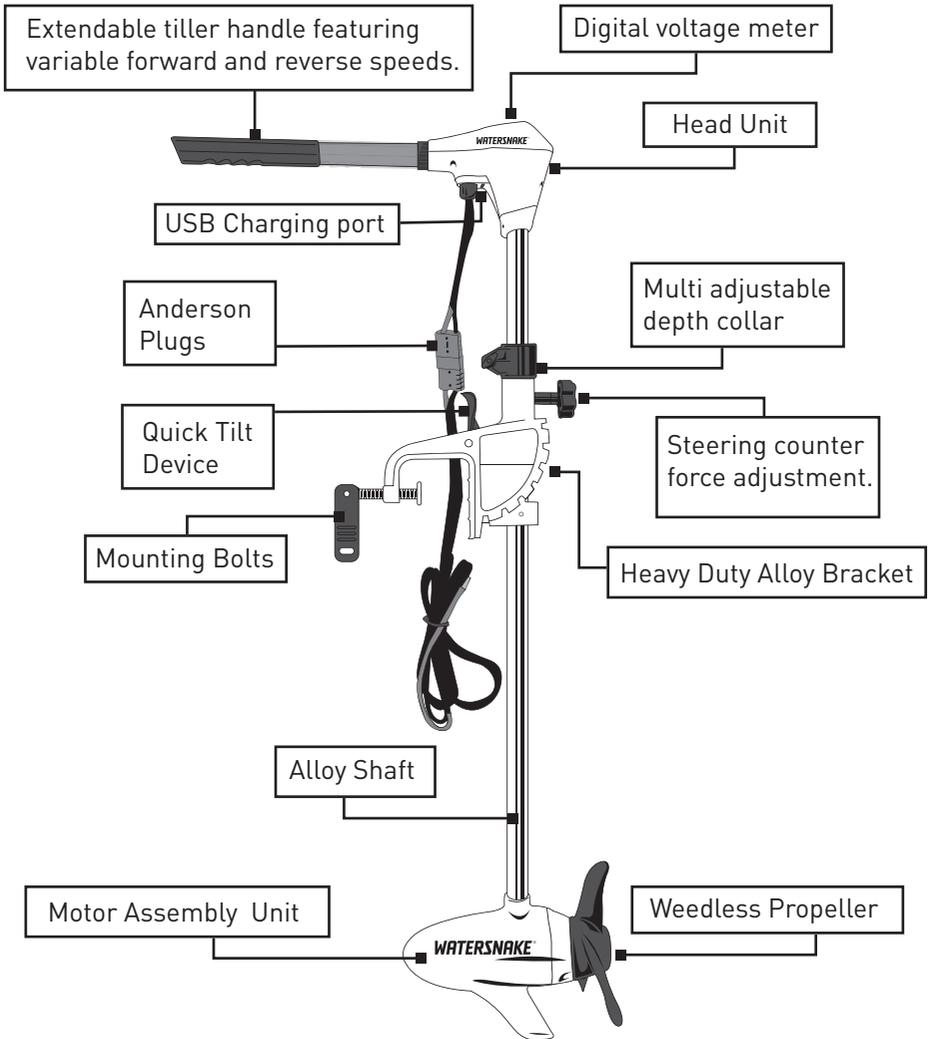

PLEASE NOTE:

Specifications are subject to change without notice. Diagram of motor is for reference only and may be different from your actual motor.

INSTALLATION

PRE INSTALLATION CHECKLIST

1. Familiarise yourself with the user manual and the various parts of your Watersnake motor.
2. Select desired mounting location on boat. Ensure there is access to properly fit the bracket in the location selected.
3. 12V deep cycle or 12V LiFePO4 battery (your Watersnake motor **IS NOT** designed for use with car / truck / motorcycle type batteries) – for more information about appropriate batteries for your Watersnake motor, refer to page 7.
4. Check battery cable length in relation to location of your 12v deep cycle or 12V LiFePO4 battery. If extension to battery cable is required, refer to table on page 8 .
NOTE – if extending battery cable, ensure that the circuit breaker remains in place on the positive wire.

PLEASE NOTE: 

TERNARY LITHIUM BATTERIES MUST NOT BE USED WITH THIS WATERSNAKE MOTOR. Refer to information on page 7.

THE BELOW INFORMATION IS FOR THE USA ONLY.



WARNING: This product can expose you to chemicals including Lead and Lead Compounds, which is known to the state of California to cause Cancer, Birth Defects or other reproductive harm. For more information, go to www.P65Warnings.ca.gov.

BATTERY AND POWER



CAUTION: Please read the following information before you connect your electric motor to your batteries.

BEST PRACTICES

INSTALLING AND CONNECTING YOUR ADVANCE MOTOR

1. Your Watersnake motor is designed to be powered by a 12v deep cycle or LifePO4 battery that should output no more than 14.5v. If the voltage input to your Watersnake motor exceeds 14.5v it may damage the sensitive electronics and void your warranty. A dedicated battery system is preferable. Do not connect other items like fish finders or lighting to the trolling motor batteries.
If you are unsure about the voltage output of your batteries, contact your battery supplier or consult a marine auto electrician.
2. This Watersnake motor is compatible with a battery system that is being charged by an alternator or solar system, so long as the voltage input to the Watersnake motor does not exceed 14.5v whilst the battery is being charged. Check this using the digital voltage meter on the head of the motor. See page 16 for more information.
3. Route the wiring from the batteries to the trolling motor on an alternate route or path to other wiring on the boat. If possible, it is preferable the wire is fitted to the opposite side of the boat to other wiring.
4. If you have to extend the wiring to connect the motor please review the extending battery leads section of the manual (page 9) so you fully understand this process.
5. This Advance trolling motor does not require a circuit breaker or inline fuse to protect the motor. See page 10 for more information.

BATTERY TYPE

USE A 12 VOLT DEEP CYCLE OR A 12V LIFEPO4 BATTERY

12V DEEP CYCLE BATTERY

Deep-cycle batteries deliver sustained power with low current draw over extended periods. They can be drained to low levels without developing a “memory” and can be fully recharged hundreds of times over their working lives. Do not use a standard car, truck or marine batteries (called a cranking battery). They are designed to provide a pulse of “cranking power” over a short period, can develop a “memory” preventing complete recharge and can produce current surges that may damage sensitive electronic components on your Watersnake.

LITHIUM BATTERIES



TERNARY LITHIUM BATTERY WARNING

Ternary Lithium batteries must not be used with this Watersnake motor as their voltage output is too high.

BATTERY AND POWER CONTINUED

12V LIFEPO4 LITHIUM BATTERY

Lithium Iron Phosphate (LiFePO₄) are the safest lithium battery type. We recommend doing your research on a LiFePO₄ battery before purchasing to make sure you are purchasing from a reputable company and the battery has a maximum voltage output under 14.5V. There are many cheap lithium batteries on the market that can be harmful to your Watersnake motor.

EXTENDING BATTERY LEADS

The longer your battery cable needs to be, the thicker it needs to be to avoid damaging voltage drop. The supplied cable has the correct wire gauge (thickness) for its length. But if you need to extend the length by more than 30%, you will need to replace the existing cable completely with a new longer thicker cable. This means the entire cable will be the correct wire gauge for the new length. See below to find the correct wire gauge for your motor thrust and required cable length. Only use twin-sheathed tinned cable.

MOTOR MODEL	MAX AMP DRAW	WIRE EXTENSION LENGTH / WIRE GAUGE FOR ENTIRE CABLE (American Wire Gauge - AWG) Note: Lower AWG# is thicker wire.		
Advance SWS 70	50A	1 Metre / 8AWG	1-3 Metres / 8AWG	3-5 Metres / 6AWG

Note that above table is intended as a guide only. Your local electrical supplier will be able to advise in greater detail based on your particular set up and requirements.

BATTERY CHARGING

Charging a battery while it is powering the motor will increase the voltage delivered to the motor. This motor can be powered by a charging battery (e.g. charging with an alternator or solar panels) as long as the voltage it receives does not exceed 14.5 volts. Exceeding 14.5 volts will potentially damage electrical components in the motor and is not covered by warranty.

When you are off the water and are charging your battery at home for long periods of time via a 240v or 110v AC charger we recommend you disconnect the motor from the battery.

AVOID USING STORE-BOUGHT BATTERY BOXES WITH BUILT-IN CIRCUITRY

Battery Boxes use low quality electrical components that cannot handle the high current loads that trolling motors draw. We recommend connecting your Watersnake motor directly to a deep cycle or LiFePO4 batteries using the provided battery leads.

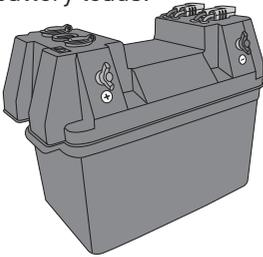

**X BATTERY BOX WITH
BUILT IN CIRCUITRY.
DO NOT USE!**

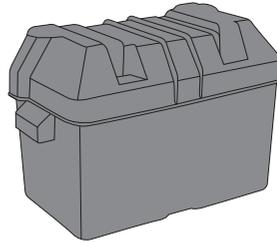

**✓ SIMPLE BATTERY
BOX WITH NO
CONNECTIONS
OK TO USE!**

CONNECTING YOUR MOTOR TO THE BATTERY

All Watersnake wiring connections should conform to best marine standards. Soldered, sealed and heat-shrink protected. If you doubt your ability to produce quality waterproof connections or lack the equipment, consult a marine technician or auto electrician.

- Your Watersnake comes factory-fitted with a standard length of twin flex wiring with ring terminals to attach to the battery.
- Before connecting the motor's cables to the battery terminals, ensure all switches are in the OFF position and stand clear of the propeller.
- Connect the red cable to the positive (+) terminal and the black cable to the negative (-) terminal, making sure the terminals are clean before doing so. A clean connection will minimise power wastage and give you maximum power from the battery.
- The voltage input must be 14.5V or lower. Voltage input above 14.5V will damage the motor and void the warranty.
- If you intend to charge your battery via an alternator or solar panel, it is important that the battery voltage output does not exceed 14.5v. If you are unsure of the voltage your battery will output, consult a marine technician or auto electrician.

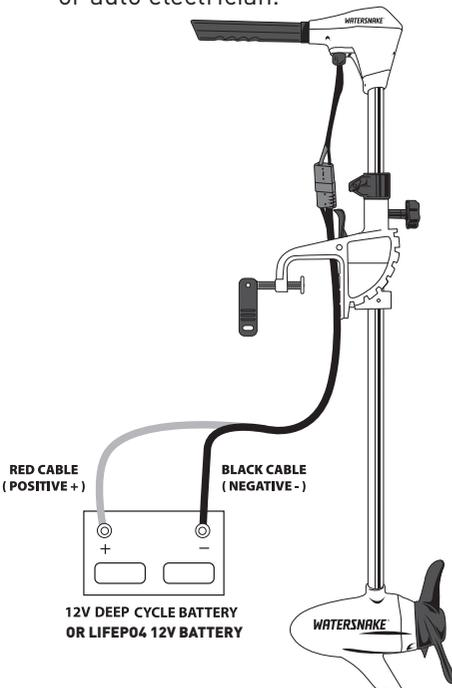

This trolling motor does not require a circuit breaker or fuse. It has built in electronics that protect the motor from excess current.

ATTACHING THE PROPELLER



WARNING: Before doing anything with the propeller, ensure the cables from the electric motor to the battery are disconnected.

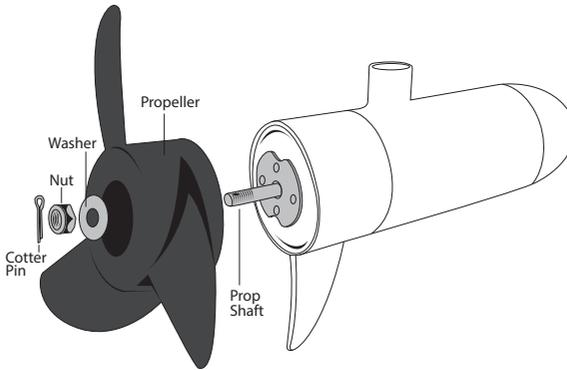

1. Place the propeller over the shaft and slide into position.

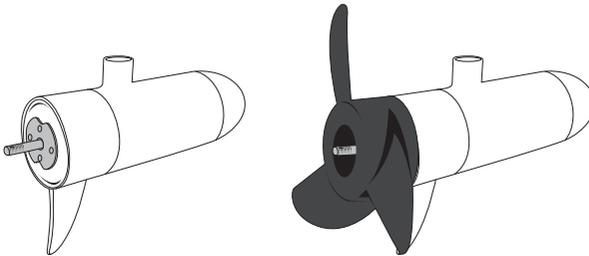

2. Place the washer over the shaft and tighten the nut with the tool provided.

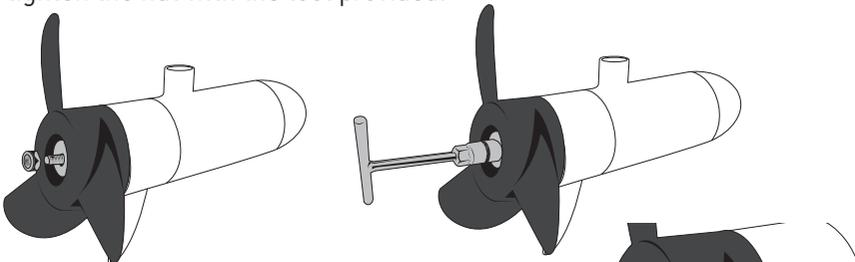

3. Insert the Cotter Pin into the hole in the shaft, bending the pin legs where they exit the shaft to stop the pin falling out.

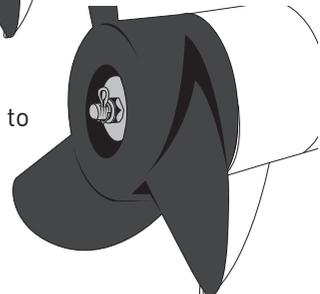

ATTACHING THE MOTOR TO YOUR BOAT

Attach the motor to the stern of the boat and tighten both mounting bolts securely while taking care not to over-tighten.

TIGHTEN BOTH BOLTS SECURELY.

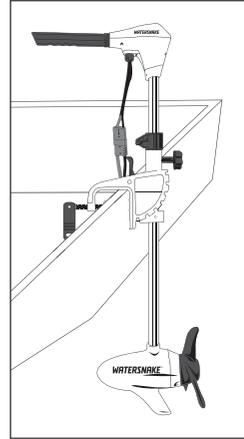
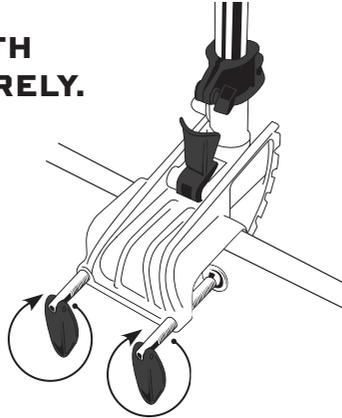

PLEASE NOTE:

Watersnake Distribution Pty Ltd accepts no liability for personal injury or property damage caused while mounting this motor.

NOTICE: It is recommended to remove the motor from the boat during long trips. Re-attach the motor to the boat when you reach your destination.

USING THE MOTOR

PRE-USE CHECKLIST – CHECK BEFORE EACH USE

- Ensure that your Watersnake motor is securely attached to your boat.
- Fully charged 12v deep cycle or 12V LiFePO4 battery. (your Watersnake motor is not designed to be used with a car / truck / motorcycle type or ternary lithium battery).
- Check battery cable for any signs of damage or exposed wiring.
- Check terminals for any signs of corrosion or debris.
- Check fuse assembly / circuit breaker – clean if any signs of corrosion or debris. Replace fuse if necessary. (If your motor is equipped with one.).

PLEASE NOTE: Please ensure this Watersnake motor is not your only means of propulsion. Please follow the marine safety guide lines set by your state or country of use.

BATTERY CHARGING

Please refer to battery charging section on page 9.

DEPLOYING YOUR MOTOR



CAUTION: Please keep your fingers and hands away from all hinge points and the propeller at all times.

To deploy your Watersnake Advance motor from its stowed position you need to loosen the depth collar and slide it up the shaft to the desired location and re-tighten. Hold the motor head or shaft with one hand and depress the quick tilt button or lever at the top of the mounting bracket with your other hand. Then carefully rotate the motor into its deployed position and set the desired depth with the depth collar.

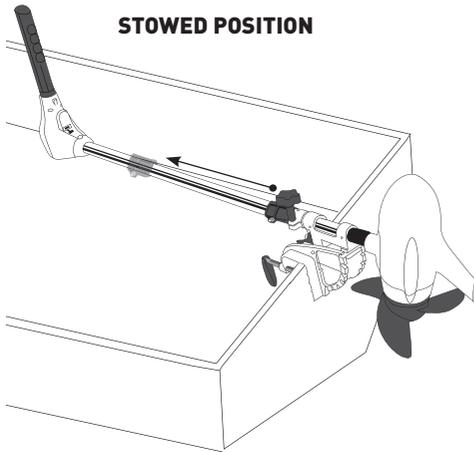

STOWED POSITION

1. SLIDE DEPTH COLLAR UP THE SHAFT TO THE DESIRED DEPTH POSITION.

2. DEPRESS THE QUICK TILT BUTTON OR LEVER TO ROTATE THE MOTOR CAREFULLY INTO ITS DEPLOYED POSITION.

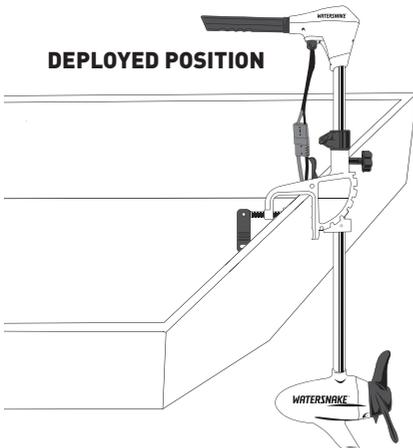
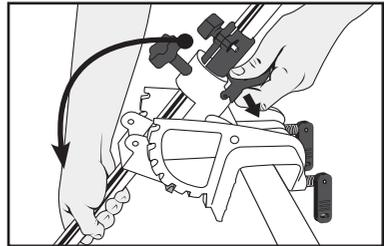

DEPLOYED POSITION

PLEASE NOTE:

Watersnake Distribution Pty Ltd accepts no liability for personal injury or property damage caused while deploying or stowing this motor.

ADJUST THE ANGLE OF THE MOTOR

To adjust the angle of the motor after attachment, hold the motor head or shaft with one hand and depress the quick tilt button or lever at the top of the mounting bracket with your other hand. Press and hold the positioning pin until the desired angle has been reached, next release the pin and ensure the mechanism locks securely.

DEPRESS THE QUICK TILT BUTTON OR LEVER TO ADJUST THE TILT OF THE BRACKET

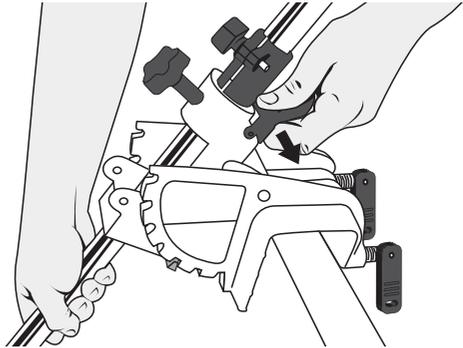

DEPTH ADJUSTMENT

Hold the motor shaft with one hand, loosen the depth collar adjustment screw and set the motor to the desired depth, then retighten the adjusting screw on the depth collar securely.

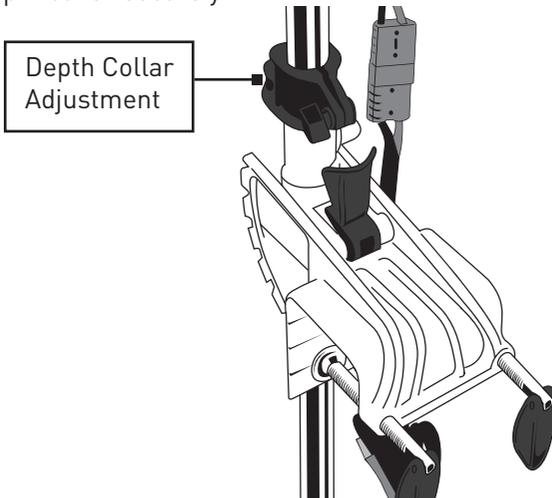

STEERING COUNTER-FORCE

The motor is steered by pivoting the Tiller Handle side-to-side. You can fine-tune the steering counter-force so the motor will stay in the direction you are aiming without the need for continual correction.

Adjust the amount of steering counter-force by loosening or tightening the counter-force bolt so it is just tight enough to maintain the same direction. **(B)**

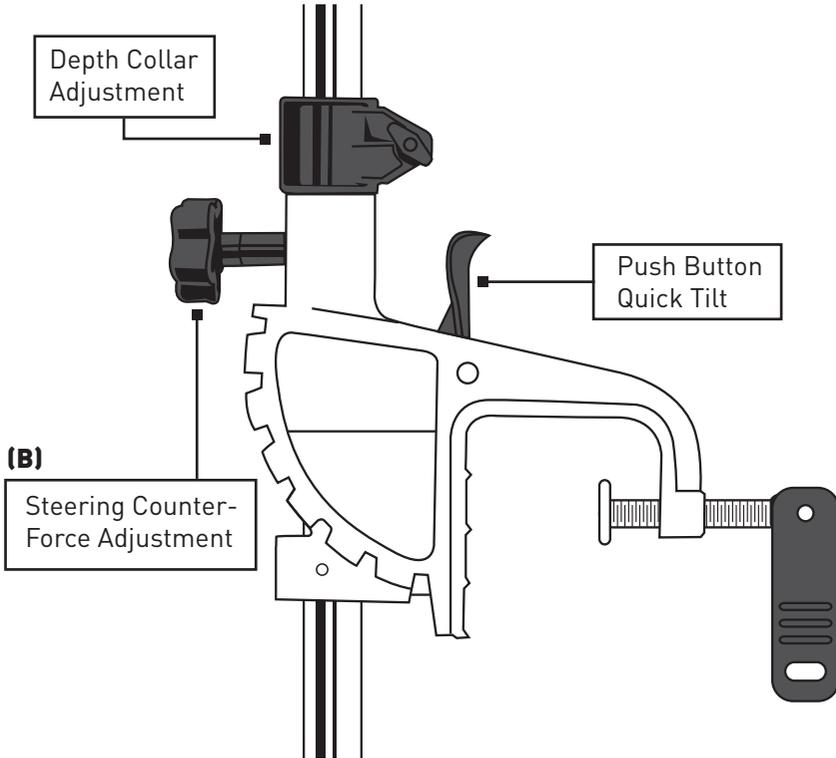

HEAD UNIT & SPEED CONTROL

The tiller handle is telescopic and can be extended. Simply pull the grip out away from the head unit to set your desired length. Rotate the handle clockwise for forward speed and anti-clockwise for reverse.

EXTENDABLE HANDLE



USB CHARGING PORT

To charge up devices like phones.



DIGITAL VOLTAGE METER

SPORTS MODE BUTTON

SPORTS MODE.

This motor can be put into high power Sports Mode for short periods by holding down the Sports Mode button. Sports Mode is for short use only. Long use may damage your motor and is not covered by warranty. Your battery will discharge at a much faster rate during the use of Sports Mode.

DIGITAL VOLTAGE METER

The Digital Voltage Meter on the motor head shows how much voltage the battery is delivering to the motor. In normal operation, the voltage should be between 12 volts and 14.5 volts, depending on your battery type. LiFoPO4 batteries will deliver a constant voltage as their charge is depleted. Deep Cycle batteries will slowly deliver less voltage as their charge is depleted - a reading of less than 12 volts indicates that your deep cycle battery is severely discharged and should not be used until it is recharged. Voltage of less than 12v will inhibit the performance of your motor.



WARNING

If the voltage on the digital voltage meter displays above 14.5 volts the motor should be disconnected from the battery.

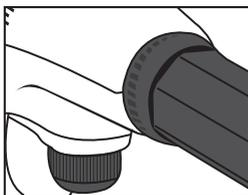

VARIABLE SPEED CONTROL

Power efficient and infinitely variable speed settings in forward and reverse.

STOWING YOUR MOTOR



CAUTION: Please keep your fingers and hands away from all hinge points and the propeller at all times.

To stow your Watersnake Advance motor from its deployed position you need to hold the motor head or shaft with one hand and depress the quick tilt button or lever at the top of the mounting bracket with your other hand. Then carefully rotate the motor into its stowed position and slide the depth collar flush to the alloy bracket and tighten it. Once the motor is in the stowed position disconnect the battery from the motor using the Anderson plugs for safe transport.

DEPLOYED POSITION

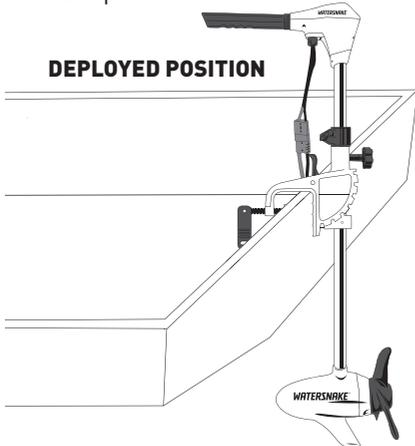

1. DEPRESS THE QUICK TILT BUTTON OR LEVER TO ROTATE THE MOTOR CAREFULLY INTO ITS STOWED POSITION.

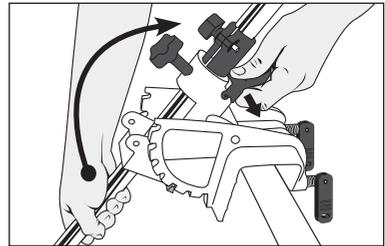

2. SLIDE DEPTH COLLAR TO BE FLUSH WITH THE MOUNTING BRACKET.

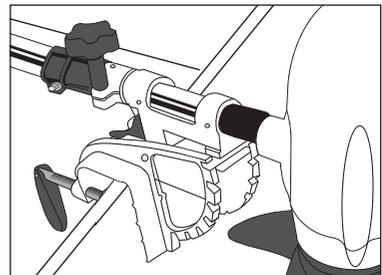

3. ONCE SECURE DISCONNECT THE BATTERY USING THE ANDERSON PLUGS FOR SAFE TRANSPORT.

PLEASE NOTE:

Watersnake Distribution Pty Ltd accepts no liability for personal injury or property damage caused while deploying or stowing this motor.

RECOMMENDATIONS

WHEN USING YOUR WATERSNAKE MOTOR IN THE WATER

Upon connecting your battery to your motor, and before setting off in your boat, make sure that your trolling motor is mounted correctly and stowed securely. Of course once you engage your Watersnake motor for use make sure that it is in the right place, not too low or too high. Once you are in deep water, you should make sure that you gradually increase the speed of your trolling motor, do not accelerate it up to full speed right away. It is recommended not to run your trolling motor out of water for long periods of time.

AFTER EVERY USE

- Disconnect motor from battery.
- Recharge battery as soon as possible.
- **DO NOT PRESSURE WASH, EVEN AFTER FRESHWATER USE.**
- Wipe your motor down with a wet rag. Concentrate on areas where salt, dirt and weed fragments are likely to lodge – propeller, motor housing, composite shaft, depth collar and exposed parts of the mount assembly.
- Wipe these areas with a cloth soaked in warm soapy water and allow to dry.
- Apply a light coating of a non-staining silicone, petroleum-based or lanolin spray to protect and lubricate exposed parts. Wipe over with a soft, dry cloth.
- Store your Watersnake motor **DISCONNECTED** from its battery.
- If boat is stored outdoors, remove Watersnake and store securely indoors in a cool, dry place.
- If Watersnake is permanently mounted to the boat outdoors, consider protecting it from harsh sunlight and the elements with a tarpaulin or other cover.

MAINTENANCE

MAINTENANCE PERIODICALLY DURING THE SEASON

- Disconnect motor from battery. Inspect battery terminals and cables for signs of corrosion. Remove buildup with a small wire brush and treat with anti-corrosion spray.
- Apply a silicone, lanolin or carnauba wax coating to the composite shaft to ensure free running through the mount assembly.

END OF SEASON, LONG-TERM STORAGE

- Disconnect motor from battery.
- Inspect battery terminals and cables for signs of corrosion.
Remove buildup with a wire brush and treat with anti-corrosion spray.
- Remove motor from boat and store in a cool, dry place away from temperature extremes.

TROUBLESHOOTING

QUICK REFERENCE GUIDE

A significant number of issues can be caused by a disruption of power supplied to your Watersnake motor. Careful inspection of your 12v battery and wiring set up should be completed before assuming that there is a fault with your motor.

NO POWER / REDUCED POWER

- Check that battery connection has not been reversed (reversed polarity)
- Check that your 12v deep cycle or LiFePO4 battery is fully charged (+ 12v)
- Check terminals / connections are secure and not loose
- Check terminals / connections for any signs of damage, corrosion or build up of debris
- If the battery cable has been extended but not replaced, you may be experiencing damaging voltage drop. Check the table on page 8 to see if you have the correct gauge wire for the length of cable extension.
- With the battery disconnected remove propeller and check for any build up of fishing line / weed or any other debris.
- Armature or magnet cracked or dislodged – grinding noise will come from motor (Contact the Watersnake distributor in your region.)

NOISE OR VIBRATION COMING FROM MOTOR

1. Disconnect the motor from the battery.
2. Note the position of the propeller blades and remove the propeller.
3. Check for and remove any buildup of fishing line/weed or other debris around the propeller shaft or propeller.
4. If the propeller has damage it may need replacing.
5. Reattach the propeller to the propeller shaft with the propeller blades rotated 180° from their original position.

STILL HAVING MOTOR ISSUES?

More information like wiring diagrams, spare parts and motor repair videos can be found on our Watersnake motor support webpage:

<https://www.watersnake.com.au/pages/electric-motor-servicing>



Scan the QR code to go to the Watersnake support page.

For more help you can also contact the Watersnake distributor for your region. (Please see the back cover.)

WATERSNAKE MOTOR ACCESSORIES SOLD SEPARATELY (SEE YOUR NEAREST DEALER FOR MORE INFORMATION)

WATERSNAKE PROPELLER KITS (SOLD SEPARATELY)

It is recommended you keep a spare propeller on your boat at all times.

55170

Advance Brushless
3 Blade Prop



**AUSTRALIA:
TO ORDER
A WATERSNAKE**

**ADVANCE PROPELLER VISIT:
www.anglerscentral.com.au**

52654

The Watersnake
Telescopic Handle
can extend to 24"
and will fit most
tiller handles.



PLEASE NOTE:

Spare parts may not be available in all areas. Please check with your local stockist. Online ordering available please see back page for details.

MOTOR SPECIFICATIONS

MODEL CODE: 55267 NAME: Advance SWS 70/36 (White Saltwater)	
VOLTAGE (V)	12v
MAX.THRUST (LB)	70lb
SHAFT LENGTH (IN)	36"
MIN. / MAX. AMP DRAW (A)	MIN.5A MAX.50A
MAX. PROP RPM (NO LOAD)	1300rpm
SPEEDS	VARIABLE FORWARD & REVERSE
PROPELLER	3 BLADE (107MM PITCH)
MOUNTING BRACKET	ALLOY TRANSOM
REQUIRED BATTERY	12v DEEP CYCLE or LiFePO4
RECOMMENDED BATTERY SIZE (AH)	100 AMP HOUR OR LARGER*
BATTERY CABLE GAUGE	8AWG
MOTOR WEIGHT	11.3kg
MAX BOAT WEIGHT (FULLY LOADED)	800kg

***NOTE** - this is to be used as a guide only. Check with your battery supplier to confirm required size of 12 volt deep cycle or LiFePO4 battery that will be appropriate for your situation.

55267 ADVANCE SWS 70/36 SCHEMATIC PAGE 1 OF 3

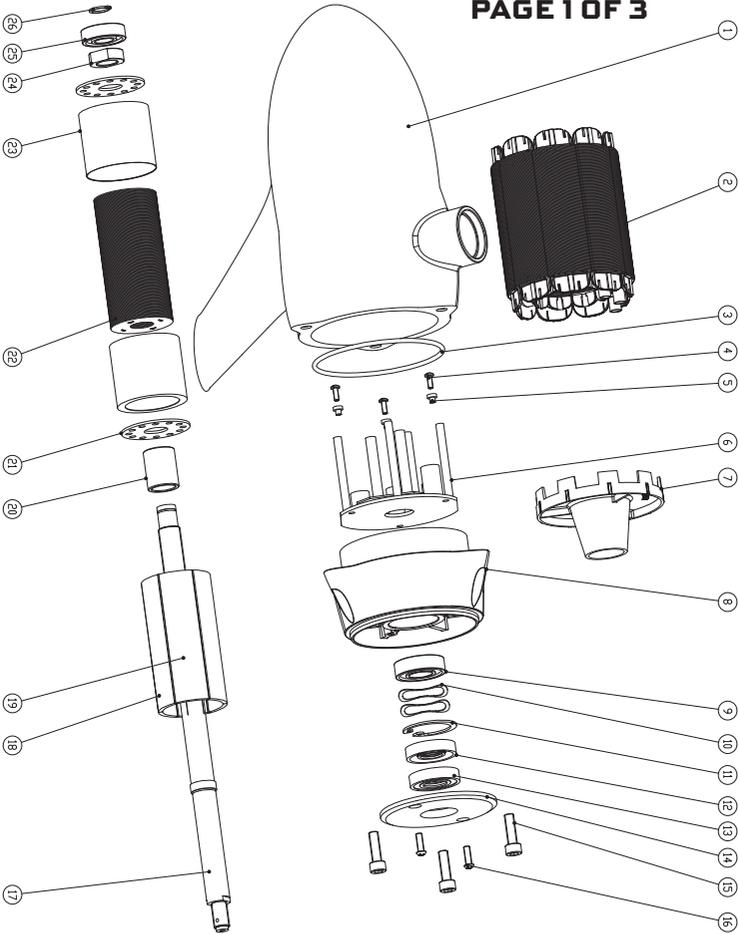

Part No.

26	HPR.247.171.016	clicklip	1
25	HPR.6263.048.001	bearing 18X28X8	1
24	HPR.378.359.016	nut	1
23	HPR.210.866.000	magnetic steel jacket	1
22	HPR.622.006.000	roller insulation layer	1
21	HP7.647.010.000	unipolar coil plate	2
20	HPR.210.869.016	slit sleeve	1
19	HPR.530.074.007	magnetic steel	3
18	HPR.530.073.007	magnetic steel	3
17	HPR.314.018.000	structure shaft	1
16	HPR.902.193.00	Screw	2
15	HPR.902.285.00	Screw	3
14	HP7.690.003.000	wedge protection block	1
13	HPR.631.124.000	absolon coil shell	1
12	HPR.683.127.000	absolon coil shell	1
11	HPR.247.170.016	inner clicklip	1
10	HPR.941.289.016	corrected elastic member	2
9	HPR.263.095.045	bearing 18X28X8	1
8	HPR.010.098.198	roller cover	1
7	HPR.210.867.000	film shafts	1
6	HPR.672.091.000	coverplate	1
5	HPR.210.870.000	cover shafts	3
4	HPR.902.201.45	cover 18X8	3
3	HPR.652.124.000	O ring	1
2	HPR.652.027.000	stator winding	1
1	HPR.034.123.198	stator housing	1
No.	DRAWING NO.	PART NAME	QTY

**AUSTRALIA:
TO ORDER
YOUR WATERSNAKE
Advance PARTS, VISIT:
www.anglerscentral.com.au**

**USA:
TO ORDER
YOUR WATERSNAKE
Advance PARTS, VISIT:
www.watersnakeusa.com**

55267 ADVANCE SWS 70/36 SCHEMATIC PAGE 2 OF 3

55267

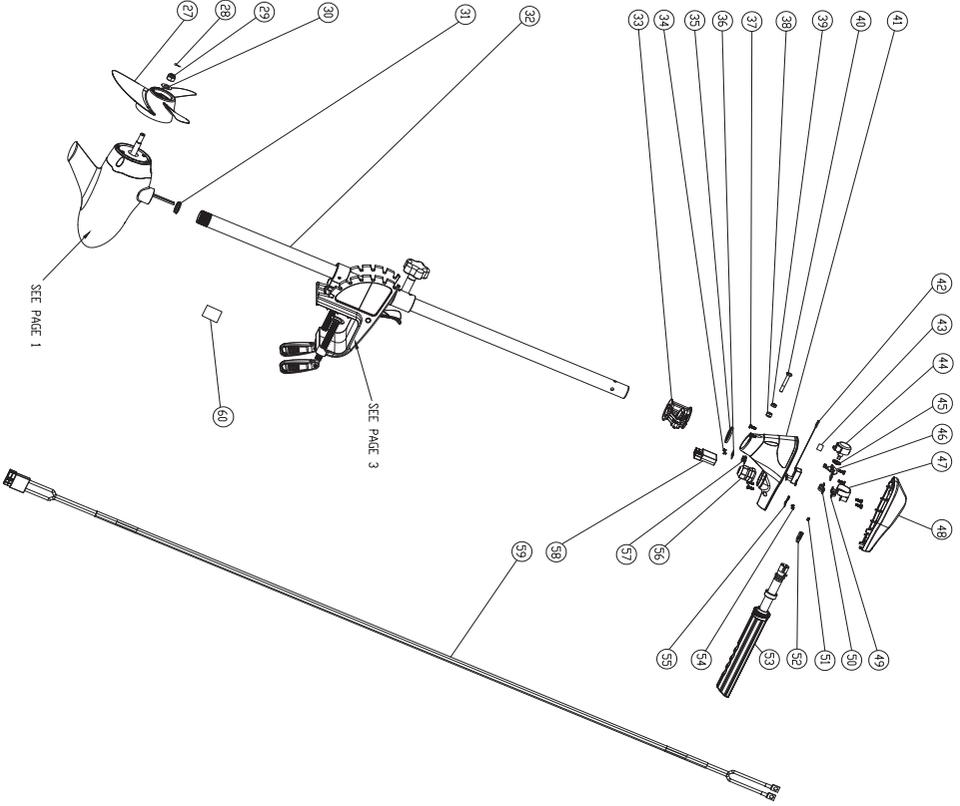

No.	DRAWING NO.	PART NAME	QTY
60	HRP.210.860.00	Bushing	1
59	HRP.647.136.00	Main battery cable	1
58	HRP.034.105.00	The connector shell	1
57	HRP.662.109.00	Seal cover	1
56	HRP.428.024.00	Water joint	1
55	HRP.387.101.00	Spring	1
54	HRP.903.078.00	Screw	2
53	HRP.465.117.00	Handle Assy	1
52	HRP.303.030.00	The connecting short	1
51	HRP.382.118.45	Spring	1
50	HRP.667.018.00	Fishing clamp top	1
49	HRP.667.032.00	Fishing clamp bottom	1
48	HRP.171.207.01	Top Cover Assy	1
47	HRP.634.116.00	Wire guard	1
46	HRP.611.102.45	The fixed frame	1
45	HRP.346.011.07	Locking Washer	1
44	HRP.630.019.00	Potentiometer assembly	1
43	HRP.672.058.00	The connector	2
42	HRP.702.067.00	USB slider-controller	1
41	HRP.076.205.70	Bottom cover	1
40	HRP.398.045.45	Ball	1
39	HRP.220.378.70	Bushing	1
38	HRP.442.003.00	Locking nut	1
37	HRP.803.058.00	Screw	8
36	HRP.610.201.45	Comp	1
35	HRP.602.083.00	Steering ring	1
34	HRP.302.143.45	Screw	2
33	HRP.257.009.00	Depth Color Assy	1
32	HRP.626.330.91	Short	1
31	HRP.210.740.00	Wire protective sleeve	1
30	HRP.394.625.00	Washer	1
29	HRP.482.006.00	Prog nut	1
28	HRP.264.569.00	Split pin	1
27	HRP.393.011.00	Prog	1
		PART NAME	
			QTY

Part No.

**AUSTRALIA:
TO ORDER
YOUR WATERSNAKE
Advance PARTS, VISIT:**
www.anglerscentral.com.au

**USA:
TO ORDER
YOUR WATERSNAKE
Advance PARTS, VISIT:**
www.watersnakeusa.com

55267 ADVANCE SWS 70/36 SCHEMATIC PAGE 3 OF 3

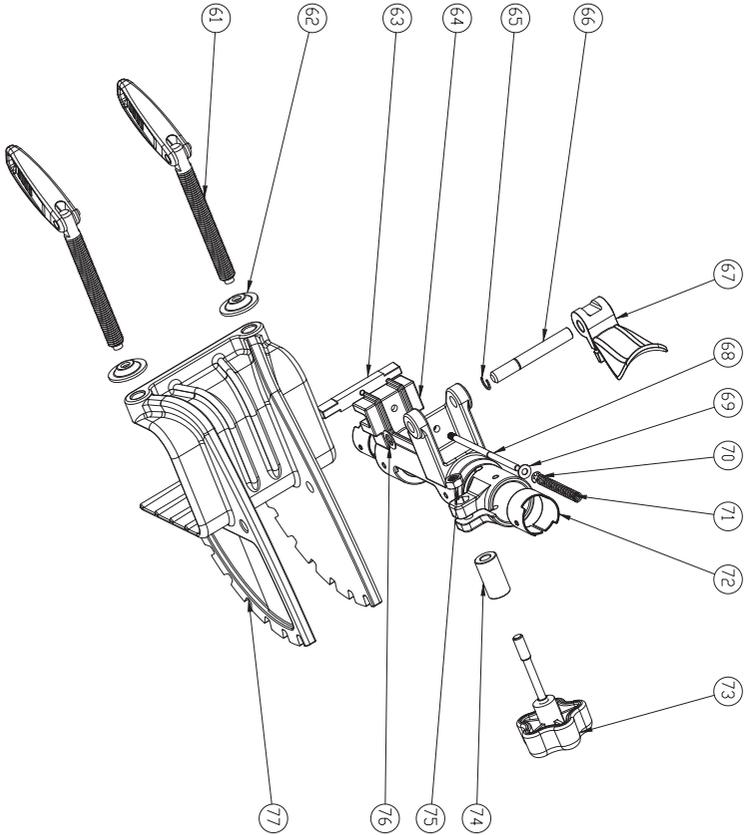

Part No.	Part Name	Qty
77	suspension brackets	1
76	washer	2
75	nut	1
74	bushing	1
73	lock handle	1
72	bushing	2
71	spring	1
70	e-shaped buckle	1
69	washer	1
68	positioning screw	1
67	wrench	1
66	axle pin	1
65	e-shaped buckle	1
64	support frame	1
63	positioning cross bar	1
62	clamping washer	2
61	bolt assy	2
	DRAWING NO.	PART NAME

AUSTRALIA:
TO ORDER
YOUR WATERSNAKE
Advance PARTS, VISIT:
www.anglerscentral.com.au

USA:
TO ORDER
YOUR WATERSNAKE
Advance PARTS, VISIT:
www.watersnakeusa.com

55267

THE BELOW INFORMATION IS FOR THE USA ONLY.



WATERSNAKE®

Watersnake Limited One Year Warranty (USA)

All watersnake products are covered by a one year Limited Warranty covering faults in workmanship and materials from the date of original retail purchase. The purchaser should return the defective product postage prepaid, insured, with proof of purchase (a dated sales receipt) and the reason for return to the address below:

**Innovative Procurement
124, Opportunity Rd, Camdenton,
MO 65020, United States
PH: +1 573-346-7447**

Online Store for spare parts and accessories: watersnakeusa.com
Note: Residents of Hawaii, Alaska, and U.S. territories shall be billed for return shipping via registered priority mail. Watersnake will repair or replace the product at its option and return direct to purchaser.

Terms

This Limited Warranty does not cover Watersnake products damaged due to abuse, misuse, normal wear, or excessive wear caused by neglect of cleaning and lubrication required or general service requirements due to owner's failure to provide reasonable and necessary maintenance.

This Warranty does not extend to products which are put into commercial use. Commercial use is defined as any work or employment related use of the product which generates income.
Watersnake products not covered by this Limited Warranty may be repaired at a nominal charge to the purchaser, provided parts are available and the product is returned with return postage prepaid.

The warranties described herein shall be the sole and exclusive warranties granted by Watersnake and shall be the sole and exclusive remedy available to the purchaser. Correction of defects, in the manner and time period described herein, shall constitute complete fulfillment of all liabilities and responsibilities of Watersnake to the purchaser with regard to this product, and shall constitute full satisfaction of all claims, whether based on contract, negligence, strict liability or otherwise. Watersnake shall not be liable or in any way responsible for any damages or defects caused by repairs or attempted repairs performed by anyone other than a Watersnake authorised service agent. Watersnake reserves the right to amend or change this Limited Warranty at any time. This Limited Warranty is non-transferable. The provisions of this Limited Warranty are in addition to, and not a modification of, or a subtraction from, the statutory warranties and other rights and remedies contained in any applicable legislation. To the extent that any provision of this Limited Warranty is inconsistent with any applicable law, such provision shall be deemed voided or amended as necessary, to comply with such law.

"ALL INCIDENTAL AND/OR CONSEQUENTIAL DAMAGES ARE EXCLUDED FROM THIS WARRANTY INSERT. IMPLIED WARRANTIES ARE LIMITED TO THE LIFE OF THIS WARRANTY. SOME STATES DO NOT ALLOW LIMITATIONS ON HOW LONG AN IMPLIED WARRANTY LASTS OR THE EXCLUSION OR LIMITATION OF THE INCIDENTAL OR CONSEQUENTIAL DAMAGES, SO THE ABOVE LIMITATIONS OR EXCLUSIONS MAY NOT APPLY TO YOU. THIS WARRANTY GIVES YOU SPECIFIC LEGAL RIGHTS, AND YOU MAY ALSO HAVE OTHER LEGAL RIGHTS THAT MAY VARY FROM STATE TO STATE."

For Your Records:

Model Number:.....

Serial Number:.....



DISTRIBUTORS

CONTACT INFORMATION

Full and up to date contact information can be found at:

www.watersnake.com.au

REGION/COUNTRY	DISTRIBUTOR	CONTACT
Asia Pacific		
Australia	Watersnake	+61 3 8789 7949
New Zealand	Brittain Wynyard	+64 9 306 7200
South Korea	Plady Co.	+82 10 9894 9938
USA		
USA	Innovative Procurement, LLC	+1 573 346 7447
Africa		
South Africa	Apex Walker	+27 11 4621 302
Europe		
Italy	Europesca Sport	+39 06 6500 2449
Sweden	Wiggler AB	+46 303 798 744
UK and Ireland	Dennet Outdoor	+44 0 2871 38 3033
Germany	World Fishing Tackle	info@wft.de

SPARE PARTS

CONTACT YOUR NEAREST DISTRIBUTOR FOR AVAILABILITY OF SPARE PARTS.

SPARE PARTS CAN ALSO BE PURCHASED ONLINE.

USA:

watersnakeusa.com

AUSTRALIA AND OTHER MARKETS:

anglerscentral.com.au

www.watersnake.com.au

Watersnake Distribution Pty. Ltd.
297-305 South Gippsland Highway
Dandenong South, Victoria 3175 Australia
ACN: 143 230 175

Watersnake® and Jarvis Marine® are registered trademarks of Watersnake Distribution Pty. Ltd.

© Watersnake Distribution Pty. Ltd. All Rights Reserved.
Specifications are subject to change without notice.