

START HERE!

READ ME FIRST

Don't be a hero and muscle through this installation without reading these fitting instructions first! Improper installation of this gear may void certain aspects of your warranty.

Before you begin, take a moment and open all your Front Runner rack kit boxes and gather the assembly instructions for the various components.

A complete kit will contain:

1. A Front Runner Mounting System specific to your vehicle
2. A Front Runner Rack Tray or Load Bar Slats

This document will guide you through the assembly of the mounting system and assist you in fitting the roof rack tray or load bars to your specific vehicle.

Please refer to the next page for a list of all the components, quantities and tools required.

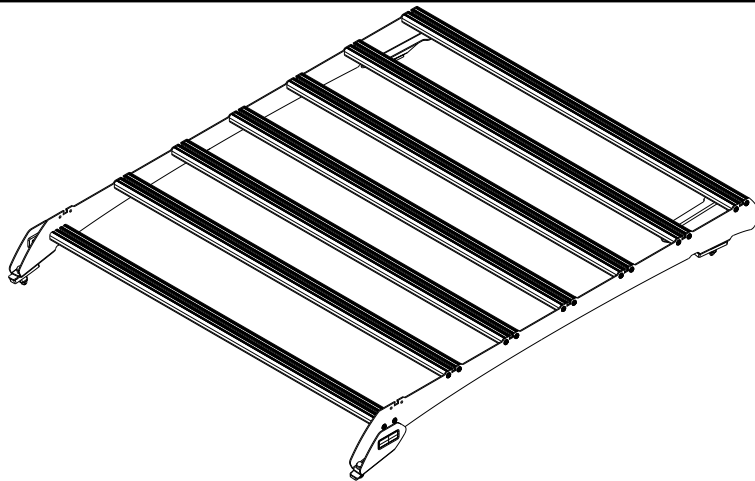

IMPORTANT WARNING!

IT IS CRITICAL THAT ALL FRONT RUNNER PRODUCTS BE PROPERLY AND SECURELY ASSEMBLED AND ATTACHED TO YOUR VEHICLE. IMPROPER ATTACHMENT COULD RESULT IN AN AUTOMOBILE ACCIDENT, AND COULD CAUSE SERIOUS BODILY INJURY OR DEATH. YOU ARE RESPONSIBLE FOR ASSEMBLING AND SECURING ALL FRONT RUNNER PRODUCTS TO YOUR VEHICLE, CHECKING THE ATTACHMENTS PRIOR TO USE, AND PERIODICALLY INSPECTING THE PRODUCTS FOR ADJUSTMENT, WEAR AND DAMAGE. THEREFORE, YOU MUST READ AND UNDERSTAND ALL OF THE INSTRUCTIONS AND PRECAUTIONS SUPPLIED WITH YOUR FRONT RUNNER PRODUCT PRIOR TO INSTALLATION OR USE. IF YOU DO NOT UNDERSTAND ALL OF THE INSTRUCTIONS AND CAUTIONS, OR IF YOU HAVE NO MECHANICAL EXPERIENCE AND ARE NOT THOROUGHLY FAMILIAR WITH THE INSTALLATION PROCEDURES, YOU SHOULD HAVE THE PRODUCT INSTALLED BY A PROFESSIONAL INSTALLER OR OTHER QUALIFIED PERSONNEL.

NOTE: Front Runner will not be responsible for any damage caused by the failure to install the product according to these instructions.

Please call us if you have any questions about the installation of this product.



1 GET ORGANIZED - FOR USA SPEC FITMENT ONLY

IN THE BOX

1	2 X	Foot Rail 1LH + 1RH
2	2 X	Wing Plate 1 LH + 1 RH
3	7 X	SlimSport Slat (1160mm Long)
4	2 X	Front Spacer - 10mm
5	2 X	Front Spacer - 6mm
6	2 X	Rear Spacer - 10mm
7	2 X	Rear Spacer - 6mm
8	28 X	M6 x 25 Thread Forming Screw
9	4 X	M6 x 40 Hex Bolt
10	8 X	M6 x 20 x 2 flat Washer
11	8 X	M6 Nyloc Nut
12	8 X	M6 Nut Cap
13	2 X	Siffener Bracket LH + RH
14	4 X	M8 x 20 Hex Bolt
15	4 X	M8 x 16 x 1.6 Flat Washer
16	4 X	M8 Nyloc Nut
17	4 X	M8 Nut Cap

TOOLS NEEDED

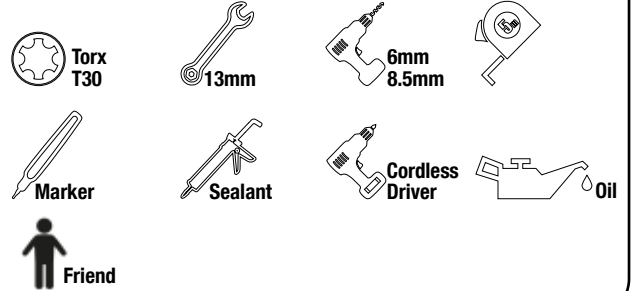
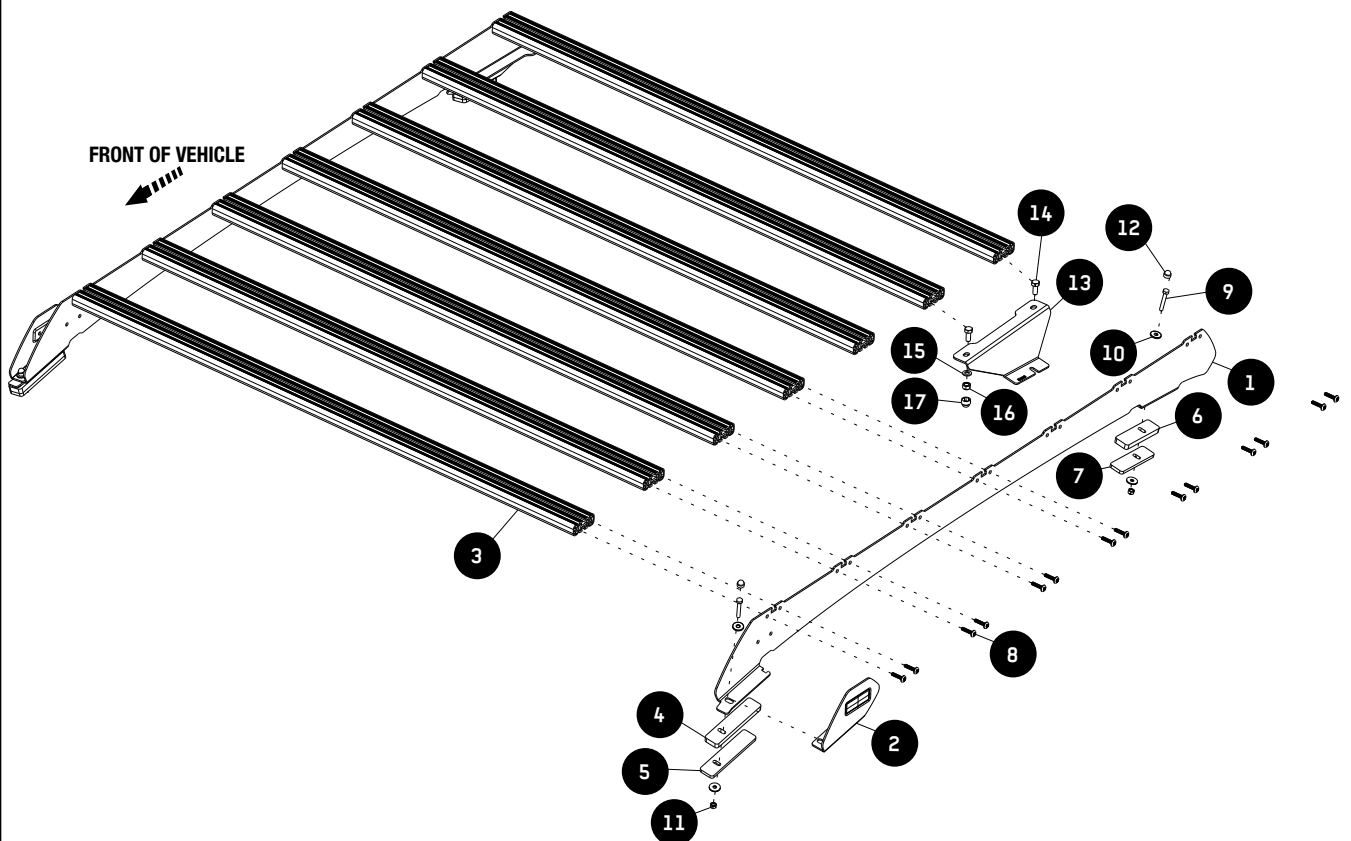

FIGURE 1.1

FOR USA SPEC FITMENT ONLY



2

FIT AND SECURE - FOR USA SPEC FITMENT ONLY

2.1



Drop the vehicle's roof lining.



Look online for videos to assist.

2.2



After the Roof Lining is dropped, Loosen the M6 nuts on the inside of the Roof holding the Ditch trim in place and remove the Ditch trim from the Roof.

2.3

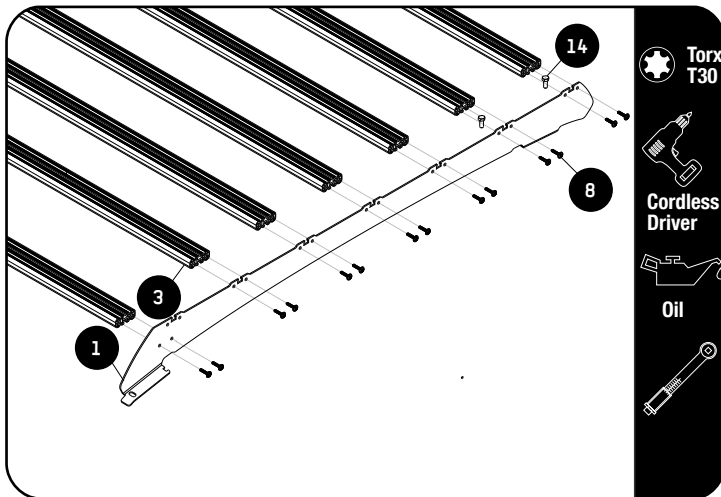

Before fitting the Foot Rails to the slats slide the 2 x M8 x 20 Hex Bolts (Item 14) into the 2 rear slats as shown to secure the support Bracket in the next step. Assemble the Footrails (Item 1) to the six rear slats (Item 3) (Leave the first slat unassembled for now) using M6 x 25 Thread Forming Screws (Item 8).



NOTE: Do not fit the front slat yet.



Apply a little oil on screw threads before inserting. Note these are thread forming screws.



Tightening Torque 8-10Nm / 5.9 ft lb - 7.38 ft lb. Take care when using a cordless driver.

2 FIT AND SECURE - FOR USA SPEC FITMENT ONLY

2.4

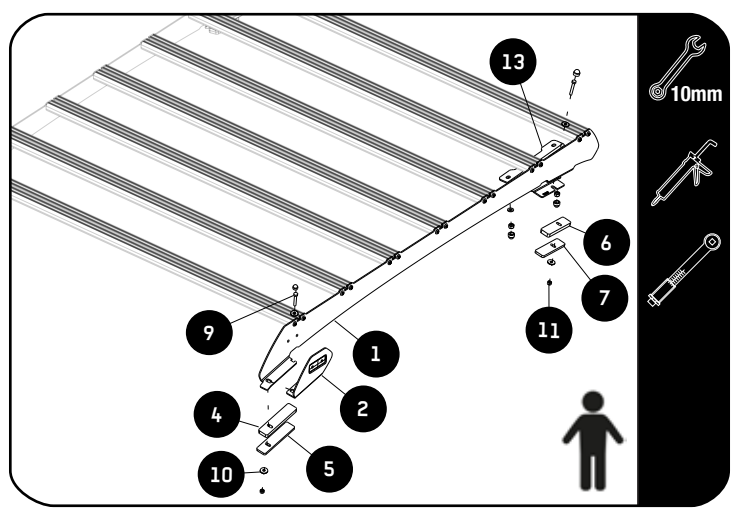

Apply a bead of sealant on the threads of the M6 x 40 Hex Bolts and secure the Foot Rail (Item 1) together with the Support Bracket (Item 13) and the Front and Rear Spacers (Item 4,5 & 6,7) to the Roof using M6 x 40 Hex Head Bolts, M6 x 20 x 2 Flat Washers and M6 Nyloc Nuts (Items 9,10 & 11).

Secure the Tray together with Front and Rear Spacers and the Wing Plates (Item 2) to the Roof using M6 x 40 Hex Bolts, M6 x 20 x 2 Flat Washers and M6 Nyloc Nuts (Items 9, 10 & 11).

Secure the Support Brackets using M8 x 16 x 1.6 Flat washer and M8 Nyloc nuts (Item 15 & 17) Fully tighten and place M8 Nut caps (Item 16) over the M8 Nyloc Nuts.

Note: Wing Plate fits above Foot Rail.

Tightening Torque:
M8 : 15-20Nm / 11.06 ft lb - 14.75 ft lb



1 GET ORGANIZED

IN THE BOX

1	2 X	Foot Rail 1LH + 1RH
2	2 X	Wing Plate 1 LH + 1 RH
3	7 X	SlimSport Slat (1160mm Long)
4	2 X	Front Spacer - 10mm
5	2 X	Rear Spacer - 10mm
6	8 X	Bottom Spacer (Non Wildtrak versions)
7	28 X	M6 x 25 Thread Forming Screw
8	4 X	M8 x 45 Hex Bolt
9	4 X	M8 x 19 x 2 Flat Washer
10	8 X	M8 Nyloc Nut
11	8 X	M8 Nut Cap
12	8 X	M8 x 16 x 1.6 Flat Washer
13	1 X	Siffener Bracket LH
14	1 X	Stiffener Bracket RH
15	4 X	M8 x 20 Hex Bolt

TOOLS NEEDED

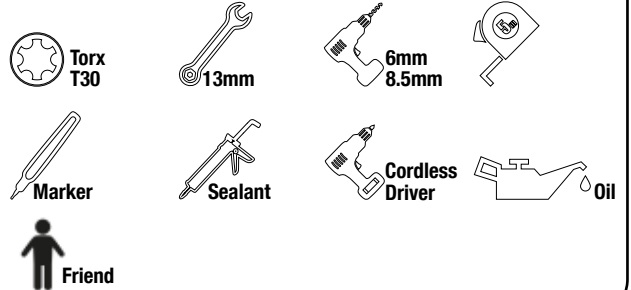
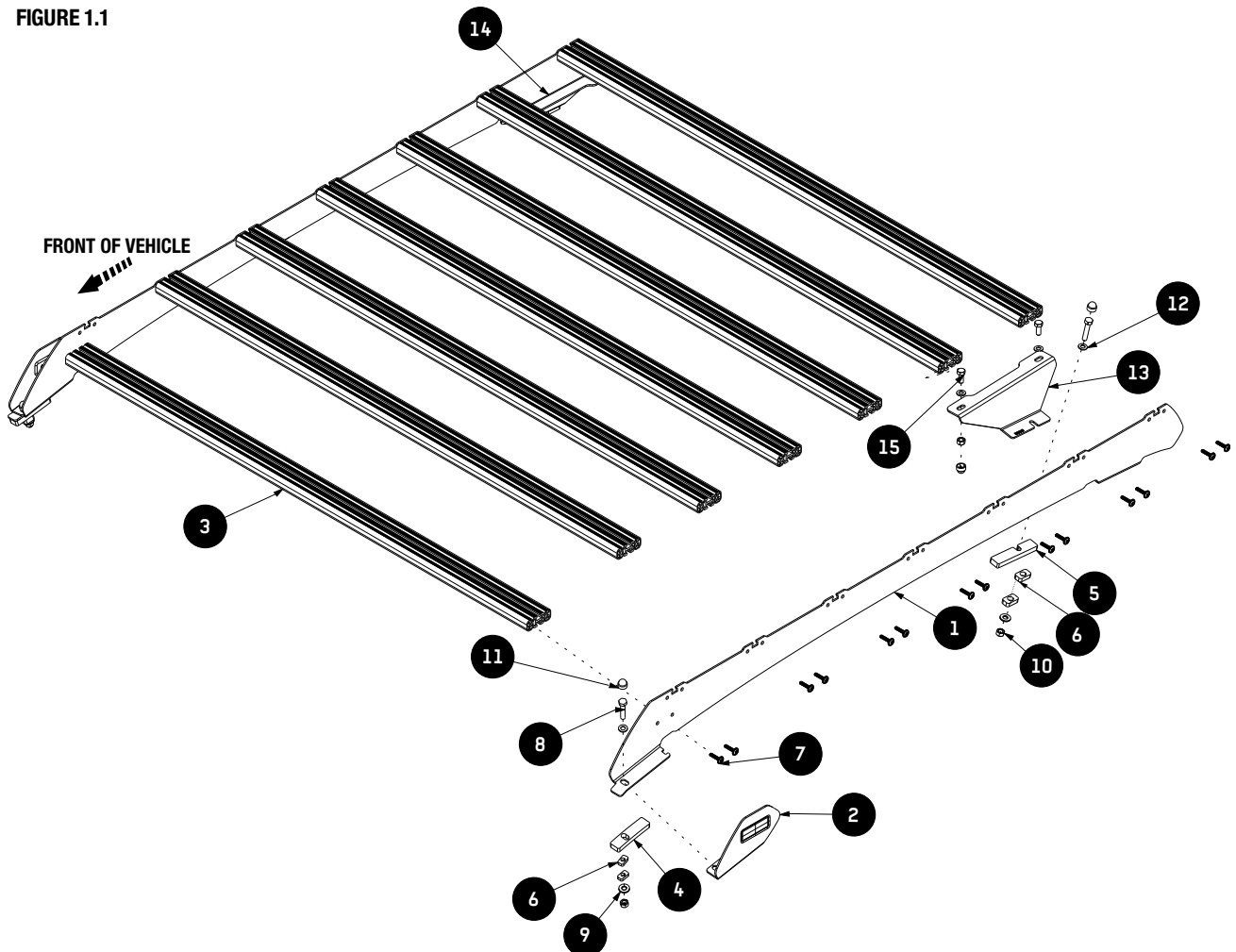

FIGURE 1.1



FIT AND SECURE - MODELS WITHOUT FACTORY ROOF RAILS

2.1



Drop the vehicle's roof lining.



Look online for videos to assist.

2.2

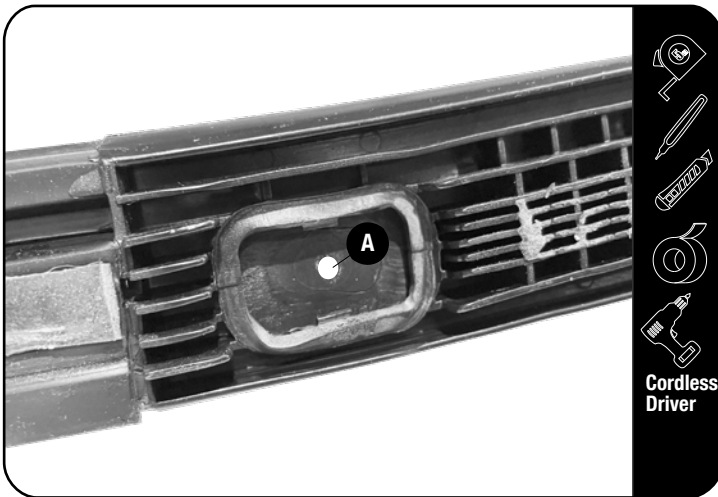

Peel back the weather strip enough so that you can remove the weather strip retaining bolt, Remove the Stud insert from the plastic trim and place the Bottom Spacer (Item 6) into the opening and mark the center of the hole (A).

Drill a 6mm Pilot hole and open it to a 8.5mm Hole.

Refit the Ditch Trim with the two Bottom Spacers (Item 6) in place.

Cordless Driver

2.3

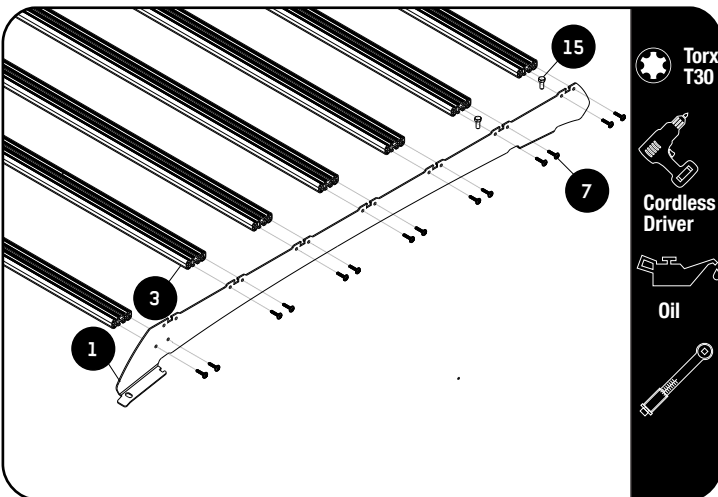

Before fitting the Foot Rails to the slats slide the 2 x M8 x 20 Hex Bolts (Item 15) into the 2 rear slats as shown to secure the support Bracket in the next step.

Assemble the Footrails (Item 1) to the six rear slats (Item 3) (Leave the first slat unassembled for now) using M6 x 25 Thread Forming Screws (Item 7).



NOTE: Do not fit the front slat yet.



Apply a little oil on screw threads before inserting. Note these are thread forming screws.



Tightening Torque 8-10Nm / 5.9 ft lb - 7.38 ft lb. Take care when using a cordless driver.

2

FIT AND SECURE - MODELS WITHOUT FACTORY ROOF RAILS

2.4

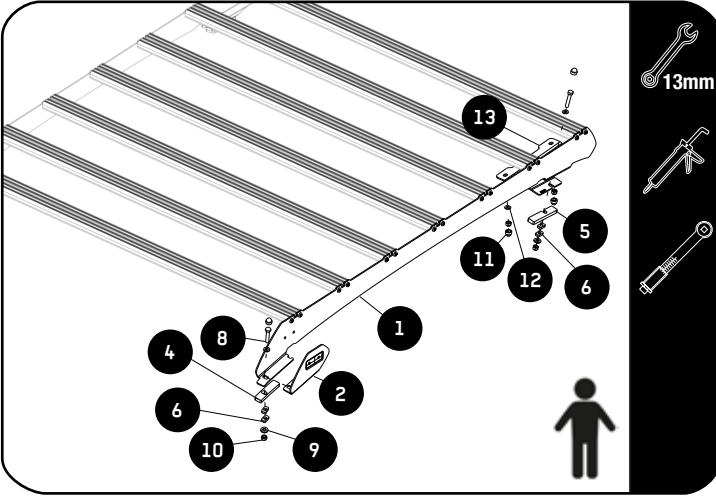

Apply a bead of sealant on the threads of the M8 x 40 Hex Bolts and secure the Foot Rail (Item 1) together with the Support Bracket (Item 13) and the Front and Rear Spacers (Item 4 & 5) to the Roof using M8 x 45 Hex Head Bolts, M8 x 19 x 2 Flat Washers and M8 Nyloc Nuts (Items 8,9 & 10).

Secure the Tray together with Front and Rear Spacers and the Wing Plates (Item 2) to the Roof using M8 x 45 Hex Bolts, M8 x 19 x 2 Flat Washers and M8 Nyloc Nuts (Items 8, 9 & 10).

⚠ Note: Wing Plate fits above Foot Rail.

Tightening Torque:
M8 : 15-20Nm / 11.06 ft lb - 14.75 ft lb

FIT AND SECURE - MODELS WITH FACTORY ROOF RAILS

3.1



🔄 Drop the vehicle's roof lining.

⚠ Look online for videos to assist.

3

FIT AND SECURE - MODELS WITH FACTORY ROOF RAILS

3.2



- Remove the OEM Rails with Ditch Trim from the vehicles roof by unbolting the nut on the inside of the roof.
- Remove the OEM rails from the Ditch Trim.

3.3



- Place a bead of Sealant on the Ditch Trim before placing it back into the vehicles ditch.
- In 3.5 you will use the supplied hardware to secure the Foot Rail/Tray onto the Ditch Trim.

3.4

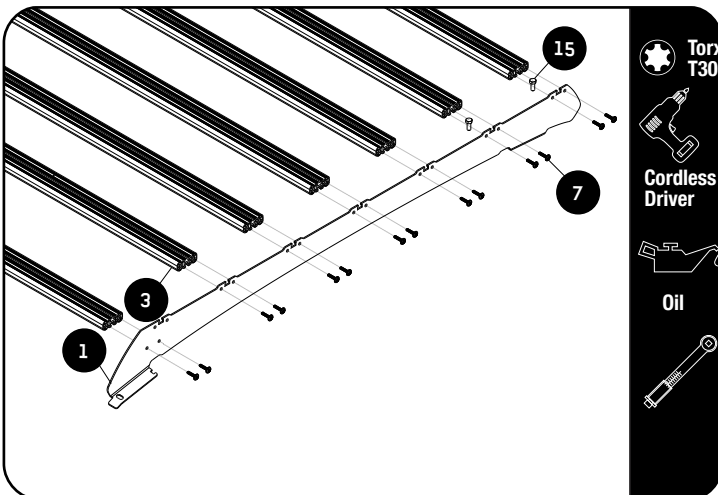

- Before fitting the Foot Rails to the slats slide the 2 x M8 x 20 Hex Bolts (Item 15) into the 2 rear slats as shown to secure the support Bracket in the next step.
- Assemble the Footrails (Item 1) to the six rear slats (Item 3) (Leave the first slat unassembled for now) using M6 x 25 Thread Forming Screws (Item 7).



NOTE: Do not fit the front slat yet.



Apply a little oil on screw threads before inserting. Note these are thread forming screws.



Tightening Torque 8-10Nm / 5.9 ft lb - 7.38 ft lb. Take care when using a cordless driver.

3

FIT AND SECURE - MODELS WITH FACTORY ROOF RAILS

3.5

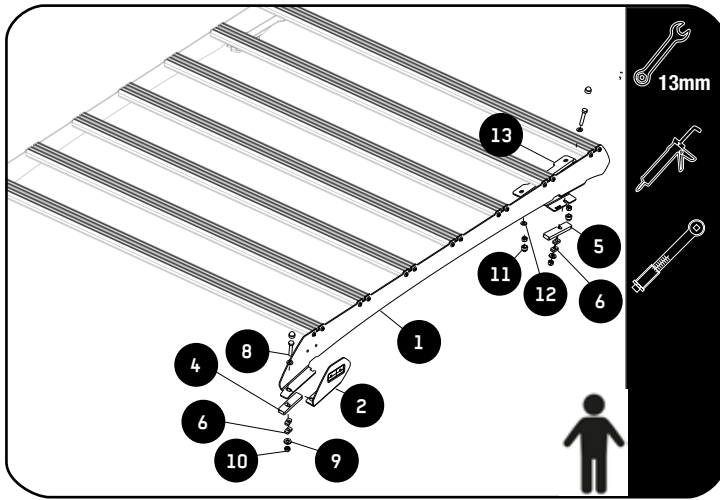

Apply a bead of sealant on the threads of the M8 x 40 Hex Bolts and secure the Foot Rail (Item 1) together with the Support Bracket (Item 13) and the Front and Rear Spacers (Item 4 & 5) to the Roof using M8 x 45 Hex Head Bolts, M8 x 19 x 2 Flat Washers and M8 Nyloc Nuts (Items 8, 9 & 10).

Secure the Tray together with Front and Rear Spacers and the Wing Plates (Item 2) to the Roof using M8 x 45 Hex Bolts, M8 x 19 x 2 Flat Washers and M8 Nyloc Nuts (Items 8, 9 & 10).



Note: Wing Plate fits above Foot Rail.



Tightening Torque:

M8 : 15-20Nm / 11.06 ft lb - 14.75 ft lb

4

FIT AND SECURE

STANDARD WIND FAIRING ASSEMBLY

4.1

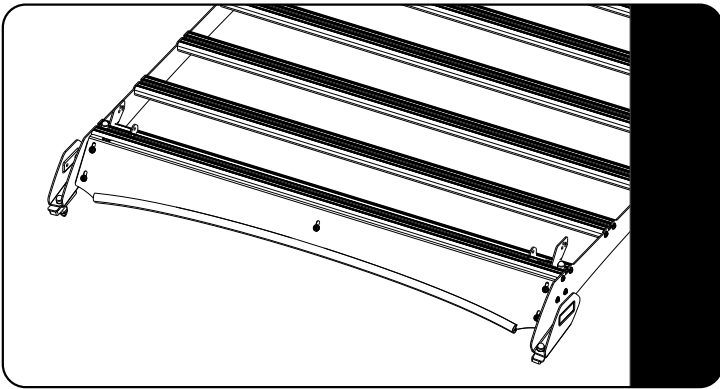

Refer to fitment guide RRAC313

LIGHT BAR WIND FAIRING ASSEMBLY

4.2

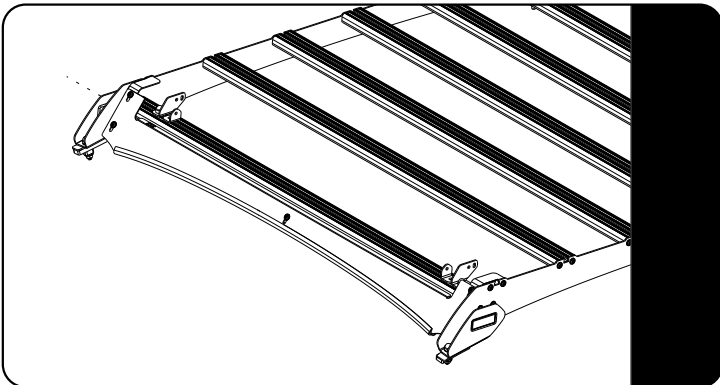

Refer to fitment guide RRAC312

5

COMPLETION

5.1

Congratulations! You did it. Take a step back and admire your work!



6

INSTALL OTHER VEHICLE AND RACK ACCESSORIES

Now's the time to visit your favorite Front Runner dealer in person or online.

IMPORTANT!

FRONT RUNNER RACK KITS OFTEN HAVE A HIGHER LOAD RATING THAN THE VEHICLES THEY ARE MOUNTED TO. PLEASE REFER TO YOUR SPECIFIC VEHICLE MANUFACTURER FOR A RECOMMENDED ROOF RATING. FRONT RUNNER CANNOT BE RESPONSIBLE FOR IMPROPER LOADING BEYOND THE VEHICLE MANUFACTURER'S STATED LOAD CAPACITY.

Be sure to tag us. We love to see our gear in action! #FrontRunnerOutfitters #BornToRoam

Share your adventures on: 