

4x4

4x4 ACCESSORIES

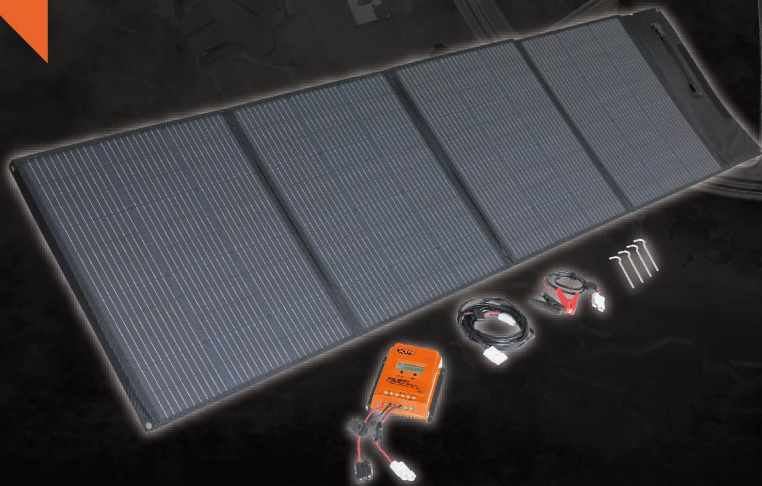

**300W
SOLAR BLANKET**

+ OWNERS/INSTRUCTION MANUAL



Please ensure that you have read the product manual and instruction in full prior to use. Failure to do so may result in incorrect operation and therefore impact on the products performance.

It is recommended this solar system is installed by an experienced professional.

SAFETY/WARNING

- Before using the XTM solar blanket ensure the instructions have been read and understood.
- The solar blanket is not intended for use by young children or infirm persons. Please keep away from pets.
- The XTM solar blanket is designed to charge most 12 volt battery types including: Flooded (Lead acid), Gel, Sealed/Mat(AGM), VRLA, Lithium Iron phosphate (LiFePO4) and Lithium Li(NiCoMn)O2 batteries.
- Always wear the appropriate Personal Protective Equipment (PPE) when working near batteries. This includes gloves and eye protection.
- Ensure battery is being charged in a well-ventilated area. Explosive gases may escape from the battery during charging. Never charge a battery in a closed off space or in an area without ventilation.
- Never smoke, use an open flame or create sparks near a battery or charger whilst charging as gases may cause explosion. Please keep burning cigarettes, flames or other ignition sources away from the charging battery at all times.
- The XTM solar blanket is not water resistant or waterproof. Do not expose the solar blanket to water or liquids.
- Do NOT attempt to use the solar blanket if the cables or plugs are damaged. These units do not contain serviceable parts. To avoid a hazard ensure that any damage to the unit, cable or plugs are replaced by a qualified technician.
- Do NOT disassemble the solar blanket. The warranty will be void if this instruction is ignored.
- If battery is still connected in the vehicle, ensure vehicle ignition is switched off before charging the battery.
- Do NOT place the solar blanket on fabric/leather/vinyl seats on the battery or balanced in the engine bay.
- Never charge a frozen battery, non-rechargeable or dry cell battery.
- Do NOT bend or scratch solar blanket.
- Do NOT walk, sit or place heavy items onto the solar blankets or the kit in the bag.
- Do NOT use a high pressure hose to clean the solar blanket. Use a clean microfibre cloth to clean solar blanket surfaces.

XTM 30A MPPT SOLAR CHARGE CONTROLLER

- **DO NOT** disassemble or attempt to repair the controller.
- Power connections must remain tight to avoid excessive heating from a loose connection.
- Only charge 12V batteries that comply with the parameters of the controller.
- Battery connection may be wired to one battery or a bank of batteries.
- Keep in a dry well-ventilated area
- Use appropriate size cable for the distance required, if unsure consult a qualified professional.

CONNECTION ORDER

Step 1. Battery Connection

1. Remove fuse from holder in battery cables.
2. Make connections to battery and controller 50A connector wired to battery symbol marked step 1 on the controller. Paying particular attention to “+” and “-”. Red to positive and black to negative on battery.
3. Install the fuses and check the LCD screen.

3a. If hard wiring, connect a fuse in the battery positive circuit, within 150mm of the battery. The fuse must be 1.25 to 2 times the rated current of the controller.

 **WARNING: If this condition is not met stop! Check connections at battery for reverse polarity and correct if necessary. If connections are continued with no LCD screen illuminated, irreparable damage will occur. This may even result in FIRE.**

STEP 2. Load Connection

1. It is recommended for heavy loads (greater than the claim on the controller) to be connected directly to the battery. All connections to be battery should be adequately fused.
2. Connect a fuse in the load positive and make connections to the wires connected to the controller marked Step 2. Paying particular attention to the polarity. When finished insert the fuse.
3. If there is no output, check the load does not exceed the current marked on the controller. If required reduce the load and continue.

STEP 3. PV Connection

1. Remove the fuse and connect the solar blanket to the 50A connector wired to the controller and marked step 3. Again, paying particular attention to the polarity then reinsert the fuse.

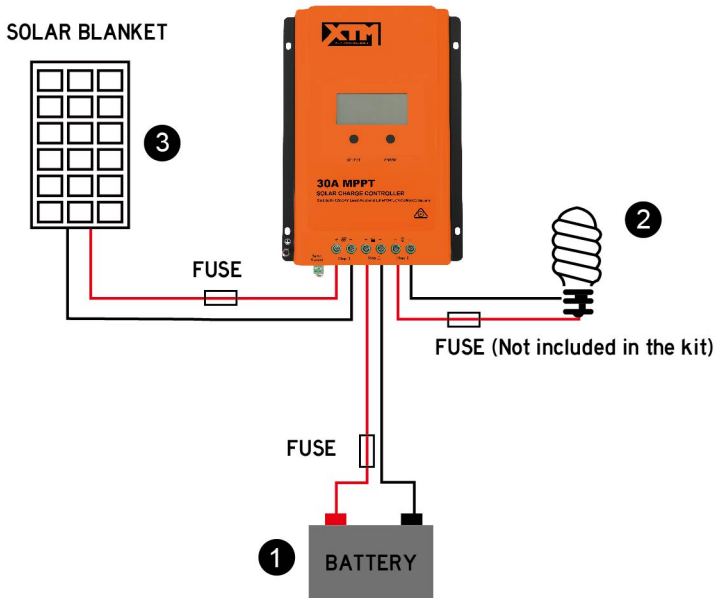

Wiring Diagram

FIRST AID & BATTERIES

- For advice, contact the Poisons Information Centre in Australia (PH:13 11 26).
- If battery acid makes contact with the skin or clothing, wash immediately with soap and water.
- If battery acid makes contact with the eyes, hold eyelids apart and flush the eye continuously with fresh running water for at least 15 minutes or until the Poisons information centre advises you to stop.
- If battery acid is swallowed, do not induce vomiting. Drink a glass of water and immediately seek medical assistance.

SPECIFICATION:

SOLAR TECHNOLOGY	High Efficiency Monocrystalline
POWER OUTPUT	300 Watt Max @ 19.80V
TESTING CONDITION	AM1.5, 1000W/m ² , 25°C
OPERATING TEMPERATURE FOR PANEL ONLY	-40°C to +85°C
ACCESSORIES	5m extension lead with 50A connectors 90cm extension lead with 50A connector and alligator clips 30A 12V MPPT controller
DIMENSIONS (mm)	720 (L) x 600 (W) x 50 (H) (folded) 2690 (L) x 720 (W) x 5 (H) (open)

CAUTION:

- **ONLY** use and store the product in a dry and well ventilated location.
- **DO NOT** use near flammable liquids or explosives.
- **STOP** use immediately if any wires become loose or electronic components are exposed.

HOW TO USE:

- Unfold the solar blanket.
- Place the solar blanket in a position directly facing the sun. Shadows will reduce optimum power output.
- Tilt the solar blanket at a suitable angle.



- Connect the solar blanket to the controller and connect the battery clamp wire to the controller.

1. The below data is the amount of electricity this solar charger can generate under full sun, and ideal working conditions.

QUANTITY	TOTAL SOLAR OUTPUT (WATT)	CHARGING CURRENT (AMP)	CHARGE CONTROLLER INCLUDED
1 Piece	300 Watt	15.2A	30A/12V

2. The solar blanket generates electricity in proportion to the amount of sunlight exposed to the solar panels. The peak generation of power is on a clear day when the sun is at a correct angle toward the solar panels. Cloud cover, seasonal variations, incidental shading and dust and dirt on the solar blanket could decrease the performance of the solar charger.

3. Power loss during transmission through lead wire and connector, efficiency of charge controller and inverter will also decrease the amount of electricity you can generate.

▲ Note:

To ensure maximum possible output, it is recommended that the Solar Blanket are regularly moved to follow the sun's movement throughout the day.

XTM 30A MPPT SOLAR CHARGE CONTROLLER

SAFETY INFORMATION

- Read all the instructions and warnings carefully in the manual before installation.
- No user-serviceable components inside the controller; please do not disassemble or attempt to repair the controller.
- Mount the controller indoors. Avoid exposure to the components and do not allow water to enter the controller.
- Install the controller in a well-ventilated place; the controller's heat sink may become very hot during operation.
- We suggest installing appropriate external fuses/breakers.
- Ensure to switch off PV array connections and the battery fuse/breakers before controller installation and adjustment.
- Power connections must remain tight to avoid excessive heating from a loose connection.

1. GENERAL INFORMATION

1.1 Overview

Adopting the advanced MPPT control algorithm, Tracer3210AN solar controller can minimize the maximum power point loss rate and loss time. It makes this product tracks the PV array's maximum power point and obtains maximum energy under any situation. Compared with the PWM charging method, MPPT solar controllers can increase the energy utilization ratio by 10%-30%. Charging current limit, charging power limit, and high temperature charging automatic power reduction; these functions fully ensure system stability when access to excess PV modules and high temperature running.

The Tracer3210AN controller owns a self-adaptive three-stage charging mode. It can effectively prolong the battery lifespan and significantly improve the system's performance. They are equipped with comprehensive electronic protections to ensure the solar system more reliable and more durable. This controller can be widely used for RV, household systems, field monitoring, and many other applications.

Features:

- Advanced MPPT, with efficiency no less than 99%
- Ultra-fast tracking speed and guaranteed tracking efficiency
- Advanced MPPT control algorithm to minimize the MPPT loss rate and loss time
- Accurate recognizing and tracking technology of multi-peaks maximum power point
- Maximum DC/DC conversion efficiency of 98%
- Automatic limitation of the charging current and charging power
- Wider MPPT working voltage range
- Support the lead-acid and lithium batteries; voltage parameters can be set on the controller
- Programmable temperature compensation feature.
- Real-time energy statistics function
- High temperature charging automatic power reduction function
- Multiple load work modes
- High quality and low failure rate components of ST or IR to ensure the service life

- 100% charging and discharging in the environment temperature range
- A power protection chip, which can provide 5VDC/200mA power and over-current, short-circuit protections, is adopted by the communication interface
- Comprehensive electronic protection

1.2 Characteristics



Figure 1-1 Product Characteristics

①	SELECT button	⑤	Load terminals
②	RTS interface	⑥	Mounting Hole $\Phi 5\text{mm}$
③	PV Terminals	⑦	ENTER button
④	Battery terminals	⑧	LCD

★ Suppose the remote temperature sensor is not connected to the controller or damaged. In that case, the controller will charge or discharge the battery at the default temperature setting of 25 °C (no temperature compensation).

1.3 Maximum Power Point Tracking Technology

Due to the nonlinear characteristics of the solar array, there is a maximum energy output point (Max Power Point) on its curve. Traditional controllers, equipped with switch charging technology and PWM charging technology, can't charge the battery at the maximum power point and cannot obtain the maximum energy available from the PV array. In contrast, the solar charge controller with Maximum Power Point Tracking (MPPT) Technology can lock the point to obtain the maximum energy and deliver it to the battery.

As Figure 1-2, the curve is also the array's characteristic curve; the MPPT technology will 'boost' the battery charge current through tracking the MPP. Assuming 100% conversion efficiency exist in the solar system, the following formula is established:

$$\text{Input power (P}_{PV}\text{)} = \text{Output power (P}_{Bat}\text{)}$$



$$\text{Input voltage (V}_{Mpp}\text{)} * \text{input current (I}_{PV}\text{)} = \text{Battery voltage (V}_{Bat}\text{)} * \text{battery current (I}_{Bat}\text{)}$$

Normally, the V_{Mpp} is always higher than V_{Bat} . Due to the principle of energy conservation, the I_{Bat} is always higher than I_{PV} . The greater the difference between V_{Mpp} & V_{Bat} , the greater the difference between I_{PV} & I_{Bat} . The greater the difference between the array and the battery will also decrease the system conversion efficiency. Therefore, the controller's conversion efficiency is particularly important in the PV system.

Figure 1-2 is the maximum power point curve, whose shaded area is the traditional solar charge controller (PWM Charging Mode). It is known that the MPPT mode can improve solar PV usage. According to the test, the MPPT controller can raise 20%-30% efficiency compared to the PWM controller. (Specified value may fluctuate due to external influences and energy loss.)

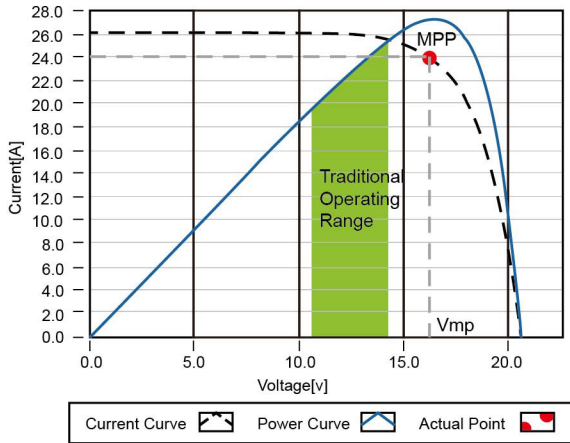

Figure 1-2 Maximum Power Point Tracking Technology

In actual application, as shading from cloud, tree, and snow, the panel may appear Multi-MPP. However, in actuality, there is only one real Maximum Power Point. As the below Figure 1-3 shows:

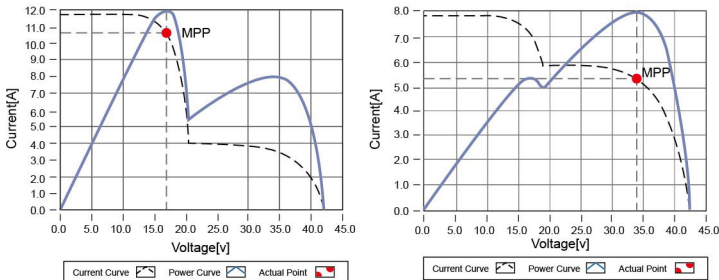

Figure 1-3 Mutil-MPP Curve

Suppose the program works improperly after appearing Multi-MPP. In that case, the system will not work on the real max power point, which may waste most solar energy resources and seriously affect the system's normal operation. The typical MPPT algorithm, can track the real MPP quickly and accurately. It can improve the PV array's utilization rate and avoid resource waste.

1.4 Battery charging stage

The controller has a three-stage battery charging algorithm, including Bulk Charging, Constant Charging, and Float Charging. Through the three-stage charging method, the system can extend the battery's lifespan.

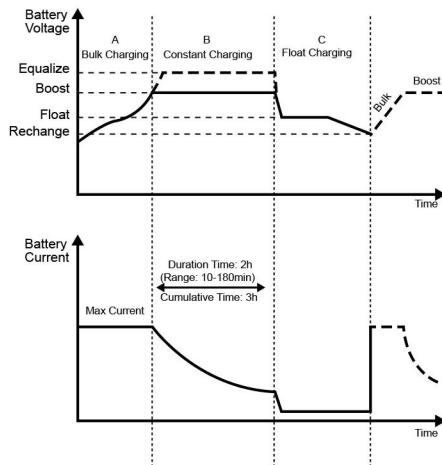

Figure 1-4 Battery charging stage curve

A) Bulk Charging

The battery voltage has not yet reached constant voltage (Equalize or Boost Charging Voltage). The controller operates in constant current mode, delivering its maximum current to the batteries (MPPT Charging). When the battery voltage reaches the constant voltage set point, the controller will start to operate in constant charging mode.



B) Constant Charging

When the battery voltage reaches the constant voltage set point, the controller will start to operate in constant charging mode. The MPPT charging stops during this process, and the charging current will drop gradually at the same time. Constant charging has two stages, namely, equalize charging and boost charging. These two charging processes are not repeated.

● Boost Charging

The default duration of the boost charging stage is generally 2 hours. Customers can also adjust the constant time and preset value according to actual needs. When the duration is equal to the set value, the system will switch to the float charging stage.

● Equalize Charging

 WARNING	<p>Explosive Risk! Equalizing flooded batteries would produce explosive gases, so well ventilation of the battery box is recommended.</p>
 CAUTION	<ul style="list-style-type: none"> ● Equipment damage! ● Equalization may increase battery voltage to the level that damages sensitive DC loads. Verify that the load's allowable input voltages are greater than the equalizing charging setpoint voltage. ● Over-charging and excessive gas precipitation may damage the battery plates and activate material shedding on them. Too high an equalize charging or for too long may cause damage. Please carefully review the specific requirements of the battery used in the system.

Some battery types benefit from equalizing charging, stirring electrolytes, balancing battery voltage, and accomplishing chemical reactions. Equalize charging increases the battery voltage to make it higher than the standard complement voltage, gasifying the battery electrolyte.

If the controller automatically controls the next charge for equalizing charging, the equalizing charging time is 120 minutes. Equalize charge and boost charge are not carried out constantly in a full charge process to avoid too much gas precipitation or overheating of the battery.

 CAUTION	<ul style="list-style-type: none"> ● Due to the installation environment or load work, the system may not stabilize the battery voltage at a constant voltage. The controller will accumulate the time when the battery voltage is equal to the set value. When the accumulative time is equal to 3 hours, the system will automatically switch to float charging. ● If the controller time is not adjusted, the controller will equalize charging following the inner time.
---	--



C) Float Charging

After the constant charging stage, the controller will reduce the battery voltage to the float charging preset voltage by reducing the charging current. During the floating charge stage, the battery is charged minimally to ensure that the battery is maintained in a fully charged state. In the float charging stage, loads can obtain almost all power from the solar panel. Suppose loads' power exceeds the solar array's power. In that case, the controller will no longer maintain the battery voltage in the float charging stage. When the battery voltage goes lower than the set value of the boost recharge voltage, the system will exit the float charging stage and enter the bulk charging stage again.

2 INSTALLATION

2.1 Attention

- Be careful when installing the batteries. Please wear eye protection when installing the open-type lead-acid battery and rinse with clean water in time for battery acid contact.
- Keep the battery away from any metal objects, which may cause a short circuit of the battery.
- Acid gas may be generated when the battery is charged. Confirm that the surrounding environment is well ventilated.
- Avoid direct sunlight and rain infiltration when installing it outdoor.
- Loose power connectors and corroded wires may result in high heat that can melt wire insulation, burn surrounding materials, or even cause a fire. Ensure tight connections and secure cables with cable clamps to prevent them from swaying in moving applications.
- Only charge the lead-acid and lithium-ion batteries within the control range of this controller.
- The battery connector may be wired to another battery or a bank of batteries. The following instructions refer to a singular battery. Still, it is implied that the battery connection can be made to either one battery or a group of batteries in a battery bank.
- Select the system cables according to $5A/mm^2$ or less current density.

2.2 Requirements for the PV array

Serial connection (string) of PV modules

As the core component of the solar system, the controller needs to suit various types of PV modules and maximize solar energy conversion into electricity. According to the open-circuit voltage (V_{oc}) and the maximum power point voltage (V_{MPP}) of the MPPT controller, the serial connection of PV modules suitable for different controllers can be calculated. The below table is for reference only.



Tracer 3210AN:

System voltage	36cell Voc < 23V		48cell Voc < 31V		54cell Voc < 34V		60cell Voc < 38V	
	Max.	Best	Max.	Best	Max.	Best	Max.	Best
12V	4	2	2	1	2	1	2	1
24V	4	3	2	2	2	2	2	2

System voltage	72cell Voc < 46V		96cell Voc < 62V		Thin-Film module Voc > 80V
	Max.	Best	Max.	Best	
12V	2	1	1	1	1
24V	2	1	1	1	1

 CAUTION	<p>The above parameters are calculated under the STC (Standard Test Condition)—module temperature 25°C, air mass 1.5, irradiance 1000W/m².)</p>
---	--

2.3 Mounting



 WARNING	<ul style="list-style-type: none"> ● Risk of explosion! Never install the controller in a sealed enclosure with flooded batteries! Do not install the controller in a confined area where battery gas can accumulate. ● Risk of electric shock! When wiring the PV modules, the PV array may generate a high open-circuit voltage. Remove the fuse firstly, and be careful when wiring.
 CAUTION	<p>The controller requires at least 150mm of clearance above and below for proper airflow. Ventilation is highly recommended if mounted in an enclosure.</p>

Installation procedures:

Step 1: Determine the installation location and heat-dissipation space



Figure 2-1 Mounting

Step 2: Connect the system in the order of battery  -- load  -- PV array  following Figure 2-2." Schematic Wiring Diagram," and disconnect the system in the reverse order.

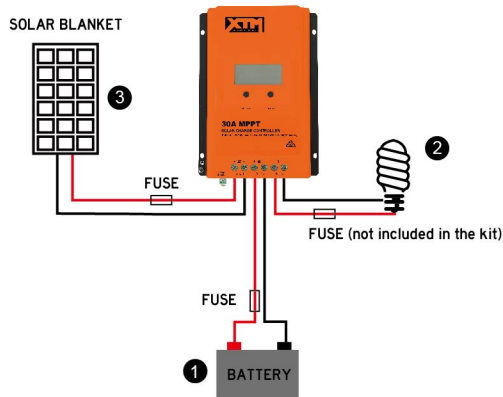

Wiring Diagram



- Please do not close the fuse during the wiring and ensure that the leads of "+" and "-" poles are polarity correctly.

Step 3: Grounding

Tracer3210AN is common-negative controller. Negative terminals of the PV array, the battery, and the load can be grounded simultaneously, or any negative terminal is grounded. However, according to the practical application, the negative terminals of the PV array, battery, and load can also be ungrounded. However, the grounding terminal on its shell must be grounded. It shields electromagnetic interference and avoids electric shock to the human body.



CAUTION

For common-negative systems, such as the RV system, it is recommended to use a common-negative controller. If a common-positive controller is used and the positive electrode is grounded in the common-negative system, the controller may be damaged.

Step 4: Connect accessories

- Connect the temperature sensor



Included Accessory

Connect one end of the remote temperature sensor to the interface.



CAUTION

Suppose the remote temperature sensor is not connected to the controller or damaged. In that case, the controller will charge or discharge the battery at the default 25 °C (no temperature compensation).

3 OPERATION

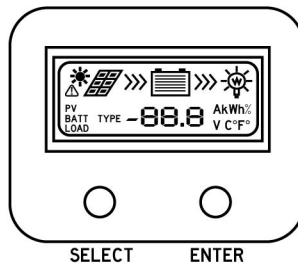







3.1 Buttons





Mode	Note
Load ON/OFF	It can turn the load On/Off via the ENTER button in manual load mode.
Clear fault	Press the ENTER button.
Browsing mode	Press the SELECT button.
Setting mode	Press the ENTER button and hold on 5s to enter the setting mode. Press the SELECT button to set the parameters. Press the ENTER button to confirm the setting parameters or no operation for 10s. It will exit the setting interface automatically.

3.2 Interface

1) Status Description

Name	Icon	Status
PV array		Day
		Night
		No Charge
		Charging
	PV	PV array's voltage, current, and generate energy
Battery		Battery capacity, In charging
	BATT.	Battery Voltage, Current, Temperature
	BATT. TYPE	Battery type
Load		Load ON
		Load OFF
	LOAD	Current/Consumed energy/Load mode

2) Error codes

Status	Icon	Instruction
Battery over-discharged		Battery level shows empty, battery frame blink, fault icon blink
Battery over voltage		Battery level shows full, battery frame blink, fault icon blink
Battery overheating		Battery level shows current value, battery frame blink, fault icon blink
Load failure		Overload ^① , Load short circuit

① When the load current reaches 1.02-1.05 times, 1.05-1.25 times, 1.25-1.35 times, and 1.35-1.5 times more than the rated value, the controller will automatically turn off the loads in 50 seconds, 30 seconds, 10 seconds, and 2 seconds respectively.

3) Browse interface

Press the SELECT button to cycle display the following interfaces.

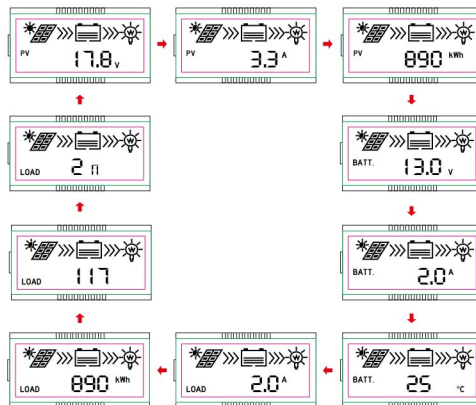

3.3 Setting

1) Clear the generated energy

Step 1: Press the ENTER button and hold 5s under the PV-generated energy interface, and the value will be flashing.

Step 2: Press the ENTER button to clear the generated energy.

2) Switch the battery temperature unit

Press the ENTER button and hold 5s under the battery temperature interface.

3) Battery type

① Support battery types

①	Battery	Sealed (default)
		Gel
		Flooded
②	Lithium battery	LiFePO4 (4S/12V, 8S/24V)
		Li(NiCoMn)O2 (3S/12V, 6S/24V, 7S/24V)
③	User	

② Set the battery type via the LCD

Operation:

Step1: Press the SELECT button to browse the battery voltage interface.

Step2: Press and hold the ENTER button until the battery-type interface flashes.

Step3: Press the SELECT button to change the battery type, shown as below.

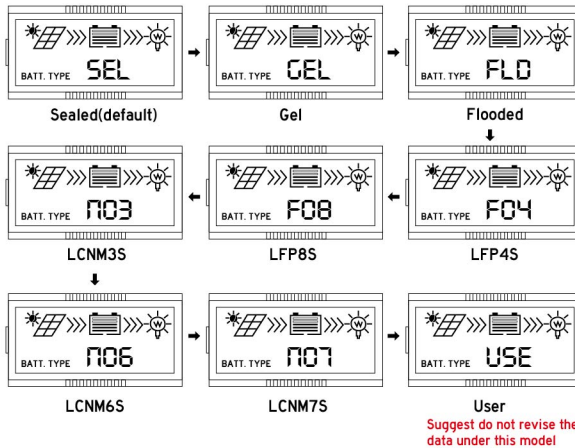

Step4: Press the ENTER button to confirm.

③ Operation:

Step1: On the battery voltage interface, press and hold the ENTER button to enter the battery type interface.

Step2: Press the SELECT button to change the battery type, such as selecting the "GEL"; and then press the ENTER button to confirm and back to the battery voltage interface automatically.

Step3: On the battery voltage interface, press and hold the ENTER button to enter the battery type interface again.

Step4: Press the SELECT button to change the battery type to the "USE". Under the "USE" battery type, the battery parameters that can be set via the LCD are shown in the table below:

Parameters	Default	Range	Operation Steps
System voltage level(SYS)*	12VDC	12/24 VDC	1) Under the "USE" interface, press the ENTER button to enter the "SYS" interface. 2) Press the ENTER button again to display the current "SYS" value. 3) Press the SELECT button to modify the parameter. 4) Press the ENTER button to confirm and enter the next parameter.
Boost charging voltage(BCV)	14.4V	9~16V	5) Press the ENTER button again to display the current voltage value. 6) Press the SELECT button to modify the parameter (short press to increase 0.1V, long press to decrease 0.1V).
Float charging voltage(FCV)	13.8V	9~16V	7) Press the ENTER button to confirm and enter the next parameter.
Low voltage reconnect(LVR)	12.6V	9~15.4V	
Low voltage disconnect voltage(LVD)	11.1V	9~15.4V	
Lithium battery protection enable (LEN)	NO	YES/NO	Press the SELECT button to modify the switch status. Note: It exists automatically from the current interface after no operation of more than 10S.

* The SYS value can only be modified under the non-lithium "USE" type. That is, the battery type is Sealed, Gel, or Flooded before entering the "USE" type, the SYS value can be modified; if it is lithium battery type before entering the "USE" type, the SYS value cannot be modified.

Only the above battery parameters can be set on the local controller, and the remaining battery parameters follow the following logic (the voltage level of 12V system is 1, the voltage level of 24V system is 2).

Battery parameters \ Battery type	Sealed/Gel/Flooded User	LiFePO4 User	Li(NiCoMn)O2 User
Over voltage disconnect voltage	BCV+1.4V*voltage level	BCV+0.3V*voltage level	BCV+0.3V*voltage level
Charging limit voltage	BCV+0.6V*voltage level	BCV+0.1V*voltage level	BCV+0.1V*voltage level
Over voltage reconnect voltage	BCV+0.6V*voltage level	BCV+0.1V*voltage level	Boost charging voltage
Equalize charging voltage	BCV+0.2V*voltage level	Boost charging voltage	Boost charging voltage
Boost reconnect charging voltage	FCV-0.6V*voltage level	FCV-0.6V*voltage level	FCV-0.1V*voltage level
Under voltage warning reconnect voltage	UVW+0.2V*voltage level	UVW+0.2V*voltage level	UVW+1.7V*voltage level
Under voltage warning voltage	LVD+0.9V*voltage level	LVD+0.9V*voltage level	LVD+1.2V*voltage level
Discharging limit voltage	LVD-0.5V*voltage level	LVD-0.1V*voltage level	LVD-0.1V*voltage level

④ Battery voltage parameters

- Measure the parameters in the condition of 12V/25°C. Please double the values in the 24V system.

Battery parameters \ Battery type	Sealed	GEL	FLD
Over voltage disconnect voltage	16.0V	16.0V	16.0V
Charging limit voltage	15.0V	15.0V	15.0V
Over voltage reconnect voltage	15.0V	15.0V	15.0V
Equalize charging voltage	14.6V	--	14.8V
Boost charging voltage	14.4V	14.2V	14.6V
Float charging voltage	13.8V	13.8V	13.8V
Boost reconnect charging voltage	13.2V	13.2V	13.2V

Battery type Battery parameters	Sealed	GEL	FLD
Low voltage reconnect voltage	12.6V	12.6V	12.6V
Under voltage warning reconnect voltage	12.2V	12.2V	12.2V
Under voltage warning voltage	12.0V	12.0V	12.0V
Low voltage disconnect voltage	11.1V	11.1V	11.1V
Discharging limit voltage	10.6V	10.6V	10.6V
Equalize Duration	120 minutes	--	120 minutes
Boost Duration	120 minutes	120 minutes	120 minutes

 CAUTION	<p>When the default battery type is selected, the battery voltage parameters cannot be modified. To change these parameters, select the "USE" type.</p>
---	---

- When the battery type is "USE," the battery voltage parameters follow the following logic:
 - A. Over Voltage Disconnect Voltage > Charging Limit Voltage ≥ Equalize Charging Voltage ≥ Boost Charging Voltage ≥ Float Charging Voltage > Boost Reconnect Charging Voltage.
 - B. Over Voltage Disconnect Voltage > Over Voltage Reconnect Voltage
 - C. Low Voltage Reconnect Voltage > Low Voltage Disconnect Voltage ≥ Discharging Limit Voltage.
 - D. Under Voltage Warning Reconnect Voltage > Under Voltage Warning Voltage ≥ Discharging Limit Voltage;
 - E. Boost Reconnect Charging voltage > Low Voltage Reconnect Voltage.

⑤ Lithium Battery voltage parameters

Battery type Battery parameters	LFP		LNCM		
	LFP4S	LFP8S	LCNM 3S	LCNM 6S	LCNM 7S
Over voltage disconnect voltage	14.8 V	29.6 V	12.8 V	25.6 V	29.8 V

Battery type Battery parameters	LFP		LNCM		
	LFP4S	LFP8S	LCNM 3S	LCNM 6S	LCNM 7S
Charging limit voltage	14.6 V	29.2 V	12.6 V	25.2 V	29.4 V
Over voltage reconnect voltage	14.6 V	29.2 V	12.5 V	25.0 V	29.1 V
Equalize charging voltage	14.5 V	29.0 V	12.5 V	25.0 V	29.1 V
Boost charging voltage	14.5 V	29.0 V	12.5 V	25.0 V	29.1 V
Float charging voltage	13.8 V	27.6 V	12.2 V	24.4 V	28.4 V
Boost reconnect charging voltage	13.2 V	26.4 V	12.1 V	24.2 V	28.2 V
Low voltage reconnect voltage	12.8 V	25.6 V	10.5 V	21.0 V	24.5 V
Under voltage warning reconnect voltage	12.2 V	24.4 V	12.2 V	24.4 V	28.4 V
Under voltage warning voltage	12.0 V	24.0 V	10.5 V	21.0 V	24.5 V
Low voltage disconnect voltage	11.1 V	22.2 V	9.3 V	18.6 V	21.7 V
Discharging limit voltage	11.0 V	22.0 V	9.3 V	18.6 V	21.7 V

- When the battery type is "USE," the Lithium battery voltage parameters follow the following logic:
 - A. Over Voltage Disconnect Voltage > Over Charging Protection Voltage (Protection Circuit Modules (BMS)) + 0.2V;
 - B. Over Voltage Disconnect Voltage > Over Voltage Reconnect Voltage = Charging Limit Voltage ≥ Equalize Charging Voltage = Boost Charging Voltage ≥ Float Charging Voltage > Boost Reconnect Charging Voltage;
 - C. Low Voltage Reconnect Voltage > Low Voltage Disconnect Voltage ≥ Discharging Limit Voltage.
 - D. Under Voltage Warning Reconnect Voltage > Under Voltage Warning Voltage ≥ Discharging Limit Voltage;
 - E. Boost Reconnect Charging voltage > Low Voltage Reconnect Voltage;
 - F. Low Voltage Disconnect Voltage ≥ Over Discharging Protection Voltage (BMS) + 0.2V

 CAUTION	The required accuracy of BMS is no higher than 0.2V. We will not assume responsibility for the abnormal when the accuracy of BMS is higher than 0.2 v.
---	--

4) Local load mode setting

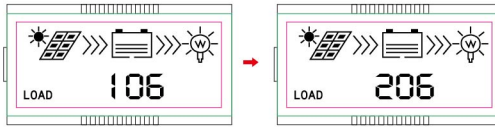

When the LCD shows the above interface, operate as follows:

Operation:

- Step1: Press the SELECT button to jump to the load type interface.
- Step2: Press and hold the ENTER button until the load type interface flashes.
- Step3: Press the SELECT button to modify the load type.
- Step4: Press the ENTER button to confirm.

① Load mode



1**	Timer 1	2**	Timer 2
100	Light ON/OFF	2n	Disabled
101	The load will be on for 1 hour since sunset	201	The load will be on for 1 hour before sunrise
102	The load will be on for 2 hours since sunset	202	The load will be on for 2 hours before sunrise

1**	Timer 1	2**	Timer 2
103~113	The load will be on for 3 ~13 hours since sunset	203~213	The load will be on for 3 ~13 hours before sunrise
114	The load will be on for 14 hours since sunset	214	The load will be on for 14 hours before sunrise
115	The load will be on for 15 hours since sunset	215	The load will be on for 15 hours before sunrise
116	Test mode	2 n	Disabled
117	Manual mode (Default load ON)	2 n	Disabled

 CAUTION	<p>When selecting the load mode as the Light ON/OFF mode, Test mode, and Manual mode, only the Timer 1 can be set; and the Timer 2 is disabled and display "2 n".</p>
---	---

4. OTHERS

4.1 Protection









No.	Protections	Instruction
1	PV Over Current	When the actual PV array's charging current or power is higher than the controller's rated charging current or power, the controller will charge the battery per the rated current or power.
2	PV short-circuit protection	When not in the PV charging state, the controller will not be damaged in the case of short-circuiting in the PV array.  WARNING: It is forbidden to short-circuit the PV array during charging. Otherwise, the controller may be damaged.
3	PV reverse polarity protection	When the PV array's polarity is reversed, the controller may not be damaged and resume work after the mis-wiring is corrected.  CAUTION: If the PV array is reversed and its actual power is 1.5 times the controller's rated power, the controller may be damaged.
4	Night reverse charging protection	Avoid the battery from discharging to the PV module at night.

No.	Protections	Instruction
5	Battery reverse protection	<p>When the polarity of the battery is reversed, the controller may not be damaged and resume normal operation after the mis-wiring is corrected.</p> <p> CAUTION: Limited to the characteristic of lithium battery, when the PV array connection right and battery connection reversed, the controller will be damaged.</p>
6	Battery over voltage protection	When the battery voltage reaches the over voltage disconnect voltage, the PV array will automatically stop charging the battery to avoid battery damage.
7	Battery over-discharging protection	When the battery voltage is lower than the low voltage disconnect voltage, the battery discharging is automatically stopped.
8	Battery overheating protection	The controller detects the battery temperature through an external temperature sensor. The battery stops working when its temperature exceeds 65°C and resumes work when it is below 55°C.
9	Lithium battery low temperature protection	When the temperature detected by the optional temperature sensor is lower than the Low-Temperature Protection Threshold (LTPT), the controller will stop charging and discharging automatically. When the detected temperature is higher than the LTPT, the controller will work automatically (The LTPT is 0°C by default and can be set within 10 ~ -40°C).
10	Load short circuit protection	When a short circuit occurs on the load side (which is 4 times higher than the rated load current), the controller automatically cuts off the output. The output still attempts to resume five times automatically (delay 5 seconds, 10 seconds, 15 seconds, 20 seconds, 25 seconds). Suppose you want the controller to restart the auto-recovery process. In that case, you need to press the Load button, or restart the controller, or experience a night-to-day change (night time >3 hours).
11	Overload protection	If the load current exceeds 1.05 times the controller's rating, the controller will cut off the output after a delay. After the overload occurs, the output attempts to resume automatically five times (delay of 5 seconds, 10 seconds, 15 seconds, 20 seconds, 25 seconds). Suppose you want the controller to restart the auto-recovery process. In that case, you need to press the Load button, or restart the controller, or experience a night-to-day change (night time >3 hours).

No.	Protections	Instruction
12	Device overheating protection	An internal temperature sensor can detect the internal temperature of the controller. The controller stops working when its internal temperature higher than 85 and resumes working when its internal temperature is below 75°C.
13	TVS high voltage transients protection	The controller's internal circuitry is designed with Transient Voltage Suppressors (TVS), which can only protect against high-voltage surge pulses with less energy. Suppose the controller is to be used in an area with frequent lightning strikes. In that case, it is recommended to install an external surge arrester.

★ When the controller's internal temperature reaches 81°C, the charging power automatic reduction function is enabled. Temperature increases by 1°C, the charging power is reduced by 5%, 10%, 20%, and 40%. If the internal temperature is higher than 85°C, the controller stops charging the battery. When the internal temperature is not more than 75°C, the controller resumes charging per the rated charging power.

4.2 Troubleshooting

Faults	Faults	Troubleshooting
PV array open-circuit	When there is plenty of direct sunlight on the PV array, the LCD shows 	Confirm whether the connection of the PV array is correct and tight
The battery voltage is lower than 8V	The wire connection is correct; the controller is not working	Please check the voltage of the battery (at least 8V voltage to activate the controller)
Battery over voltage	  Battery frame blink	Check whether the battery voltage is higher than OVD (over voltage disconnect voltage) and disconnect the PV array connection
Battery over discharged	  Battery frame blink	① When the battery voltage is restored to or above LVR (low voltage reconnect voltage), the load will recover. ② Take other ways to recharge the battery
Battery overheating	  Battery frame blink	While the temperature decline to be below 55 °C, the controller will resume
Overload	1. Load off	① Please reduce the number of electric devices. ② Restart the controller or press the button to clear faults
Load short-circuit	2.   Load and fault	① Check carefully loads connection, clear the fault. ② Restart the controller or press the button to clear faults

① When the load current goes higher than 1.02-1.05 times, 1.05-1.25 times, 1.25-1.35 times, and 1.35-1.5 times the rated value, the controller may automatically turn offloads in 50 seconds, 30 seconds, 10 seconds, and 2 seconds respectively.

4.3 Maintenance

The following inspections and maintenance tasks are recommended at least two times per year for good performance.

- Make sure no block on airflow around the controller. Clear up any dirt and fragments on the radiator.
- Check all the naked wires to ensure insulation is not damaged for sun exposure, frictional wear, dryness, insects or rats, etc. Repair or replace some wires if necessary.
- Verify the indicator display is consistent with the actual operation. Pay attention to any troubleshooting or error conditions. Take necessary corrective action.
- Confirm that terminals have no corrosion, insulation damaged, high temperature, burnt/discolored sign, and tighten terminal screws to the suggested torque.
- Clear up dirt, nesting insects, and corrosion in time.
- Check and confirm that the lightning arrester is in good condition. Replace a new one in time to avoid damaging the controller and even other equipment.



CAUTION

Risk of electric shock! Ensure that the power is turned off before the above operations, and then follow the corresponding inspections and operations.

5 SPECIFICATIONS

Electrical Parameters

Parameter	Tracer 3210AN
Electrical Parameters	
System rated voltage	12/24VDC ^① Auto-recognition
Rated charging current	30A
Rated discharge current	30A
Controller working voltage range	8~32V
Max. PV open circuit voltage	100V ^② 92V ^③
MPPT voltage range	(Battery voltage +2V)~72V
PV rated charge power	390W/12V 780W/24V
Self-consumption	≤12mA

Discharge circuit voltage drop	≤ 0.23V
Temperature compensate coefficient ^④	-3mV/°C/2V:(Default)
Parameter	Tracer 3210AN
Grounding type	Common negative
LCD backlight time	60S
Environmental parameters	
Environment temperature ^⑤	-25°C~+45°C (100% loads working)
Storage temperature	-20°C~+70°C
Relative humidity	< 95% (N.C.)

- ① When a lithium battery is used, the system voltage can't be identified automatically.
- ② At minimum operating environment temperature
- ③ At 25°C environment temperature
- ④ When a lithium battery is used, the temperature compensation coefficient will be 0 and can't be changed.
- ⑤ The controller can full load working in the working environment temperature. When the internal temperature reaches 81°C, the reducing charging power mode is turned on. Refer to chapter 4.1 Protection.

Mechanical parameters

Model	Tracer 3210AN
Dimension	228x164x55mm
Mounting dimension	170x155mm
Mounting hole size	Φ5mm
Net Weight	1.26kg

6. DISCLAIMER

Under the following conditions, product warranty does not cover/apply:

- Damage caused through misuse, including use within unsuitable environments.
- Damage caused as a result of PV, load current, voltage or power exceeding the rated value of the controller.
- Damage caused from use in excessively hot environments.
- If the controller has been disassembled, opened or altered by the user
- Damage caused from natural elements, for example lightning.
- Damage caused during transportation by the user.
- **Damage caused by exposing connections to water.**

ANNEX I CONVERSION EFFICIENCY CURVES

Test condition: Illumination Intensity: 1000W/m² Temperature: 25

Model: Tracer3210AN

1. PV array Max. power point voltage (17V, 34V)/system voltage (12V)

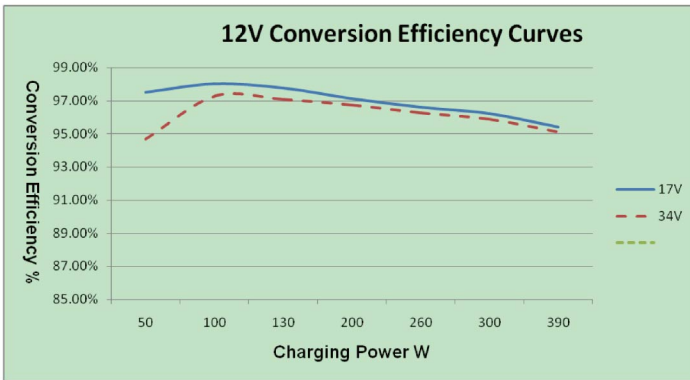

2. PV array Max. power point voltage (34V, 51V, 68V)/system voltage (24V)

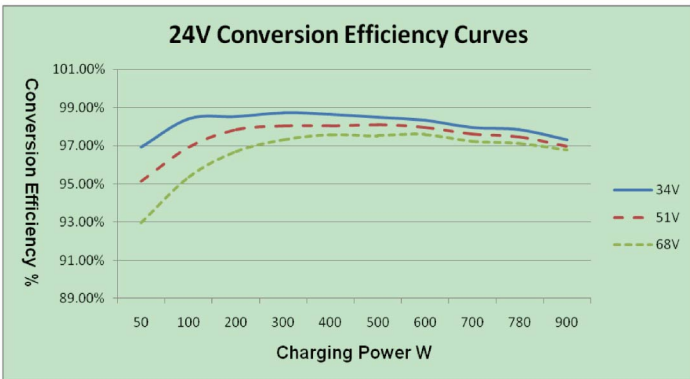

FREQUENTLY ASKED QUESTIONS

Q. What type of batteries can be used with the solar blanket kit?

A. Flooded(Lead acid), Gel, Sealed/Mat(AGM), VRLA, Lithium Iron phosphate (LiFePO4) and Lithium Li(NiCoMn)O2 batteries.

Q. Will the solar blanket over charge my battery?

A. No. The solar blanket solar charge controller ensures that a steady charge is supplied to the battery without over charging.

Q. Can I extend or lengthen the battery lead wire?

A. If the lead is extended, this can result in a loss of voltage causing insufficient power being transferred from the solar blanket. Use appropriate size cable for the distance required, if unsure consult a qualified professional. Product modifications will void your warranty.

Q. How do I clean the solar blanket?

A. Dust & dirt should first be swept off the panel surface using a soft brush or a microfibre cloth. Then, using a clean microfibre cloth, wipe the solar panel surfaces to remove remaining dirt & grime. It is recommended that any bird droppings be removed as soon as possible to avoid surface damage.

Q. Is the solar blanket waterproof or water resistant?

A. No, the solar blanket is not waterproof or water resistant. Do not expose the solar blanket to water or liquids.

NOTE: Do not expose connections to water.

Q. Is the 12V 30A MPPT solar charge controller waterproof?

A. No, the controller is not waterproof or water resistant.

NOTE: Do not expose connections to water.

Q. What is photovoltaic?

A. The photovoltaic(PV) effect are solar cells that produce direct current electricity from sunlight which can be used to power equipment or to recharge a battery.



WARRANTY

Our product is guaranteed to be free from quality and manufacturing defects for a period of 12 months.

If your product becomes defective during this period, SRGS PTY LTD will offer you either a replacement, credit or refund where a product is faulty; wrongly described; different from the sample shown to you or do not do what they are supposed to do.

This warranty will not cover substantially modified product; misuse or abuse of the product contrary to user instructions or packaging label; change of mind and normal wear and tear.

Our goods come with guarantees that cannot be excluded under the Australian Consumer Law. You are entitled to a replacement or refund for a major failure and for compensation for any other reasonably foreseeable loss or damage. You are also entitled to have the goods repaired or replaced if the goods fail to be of acceptable quality and failure does not amount to a major failure.

To claim the warranty, take the product to the front Service Desk of your nearest store of purchase. You will need to show receipt or other proof of purchase. Additional information may be required to process your claim. Should you not be able to provide proof of purchase with a receipt or bank statement, identification showing name, address and signature may be required to process your claim.

Any expenses relating to the return of your product to the store will normally have to be paid by you. For online store purchases, SRGS PTY LTD will pay for the return freight for any product assessed as having a major failure.

The benefits to the customer given by this warranty are in addition to other rights and remedies of the Australian Consumer Law in relation to the goods or services to which this warranty relates.

This warranty is provided by SRGS PTY LTD, 6 Coulthards Avenue, Strathpine QLD 4500, Australia. Phone: 1300 880 764.



PLU	690316
Construction	Monocrystalline solar panels
Max power (Nom.)	300W
Dimensions (folded)	720x600x50mm
Dimensions (open)	2690x720x5mm
Max power voltage	19.8V
Max power current	15.2A
Open circuit voltage	23.76V
Short circuit current	17.6A
Power Tolerance	±3%
Cable length	5+0.9 Metre
Operating temperature for panel only	-40°C to +85°C
Standard test conditions	AM1.5 1000W/m ² 25°C
Manufactured in	China



PLU: 690316 CODE: 300WBLANKET

Manufactured & packaged for

SRGS PTY LTD

ABN 23 113 230 050

6 Coulthards Avenue Strathpine QLD 4500, Australia

MADE IN CHINA