

XTM

4x4 ACCESSORIES



**120W FIXED
SOLAR PANEL**

+ OWNERS/INSTRUCTION MANUAL



Please ensure that you have read the product manual and instruction in full prior to use. Failure to do so may result in incorrect operation and therefore impact on the products performance.

SAFETY/WARNING

- Before using the XTM solar panels ensure the instructions have been read and understood.
- The solar panels are not intended for use by young children or infirm persons. Please keep away from pets.
- Always wear the appropriate Personal Protective Equipment (PPE) when working near batteries. This includes gloves and eye protection.
- Ensure battery is being charged in a well-ventilated area. Explosive gases may escape from the battery during charging. Never charge a battery in a closed off space or in an area without ventilation.
- Never smoke, use an open flame or create sparks near a battery or charger whilst charging as gases may cause explosion. Please keep burning cigarettes, flames or other ignition sources away from the charging battery at all times.
- Do NOT attempt to use the solar panels if the cables or plugs are damaged. These units do not contain serviceable parts. To avoid a hazard ensure that any damage to the unit, cable or plugs are replaced by a qualified technician.
- Do NOT disassemble the solar panels. The warranty will be void if this instruction is ignored.
- Do NOT place the solar panels on fabric/leather/vinyl seats on the battery or balanced in the engine bay.
- If the battery is still connected in the vehicle, ensure vehicle ignition is switched off before charging the battery.
- Never charge a frozen battery, non-rechargeable or dry cell battery.
- The XTM solar panels may have sharp edges-please handle with care.
- Do NOT bend or scratch solar panels.
- Do NOT walk, sit or place heavy items onto the solar panels.
- Do NOT use a high pressure hose to clean the solar panels. Use a clean microfibre cloth to clean solar panels surfaces.

FIRST AID & BATTERIES

- For advice, contact the Poisons Information Centre in Australia (PH:13 1126)
- If battery acid makes contact with the skin or clothing, wash immediately with soap and water.
- If battery acid makes contact with the eyes, hold eyelids apart and flush the eye continuously with fresh running water for at least 15 minutes or until the Poisons information centre advises you to stop.
- If battery acid is swallowed, do not induce vomiting. Drink a glass of water and seek medical assistance.

SPECIFICATION:

SOLAR TECHNOLOGY	High Efficiency Monocrystalline
POWER OUTPUT	120 Watt Max @ 21.5V
TESTING CONDITION	AM1.5, 1000W/m ² , 25°C
OPERATE TEMPERATURE	-40°C to + 85°C
ACCESSORIES	90cm Cable
DIMENSION	1070x580x17mm

CAUTION:

- Use and store the product in a dry and well ventilated location.
- Do not use near flammable liquids or explosives.
- Stop use immediately if any wires become loose or electronic components are exposed.
- The panel is to be used in conjunction with a charge controller and that the charge controller is not supplied.
- It is high recommended to add a fuse when connecting to a charge controller.

DIAGRAM

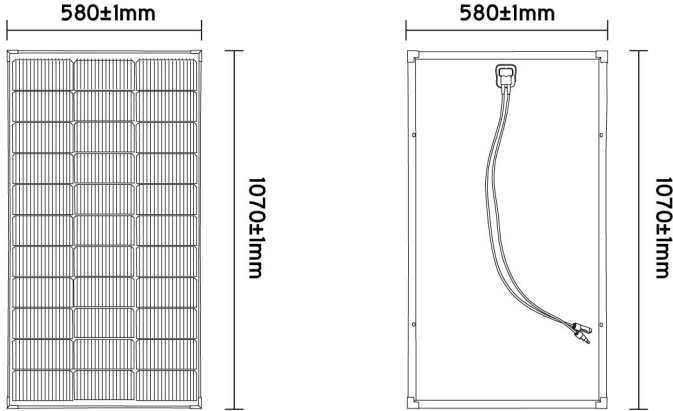

MOUNT KIT IS NOT INCLUDED (SOLD SEPARATELY)

SERIAL NO.	DESCRIPTION OF PARTS	QUANTITY
1	Mounting brackets	4
2	Short bolts	4
3	Lock nuts	4
4	Fender washers	4
5	Flat washers	8
6	Spring washers	12
7	Long bolts	8
8	Threaded brace plates	4

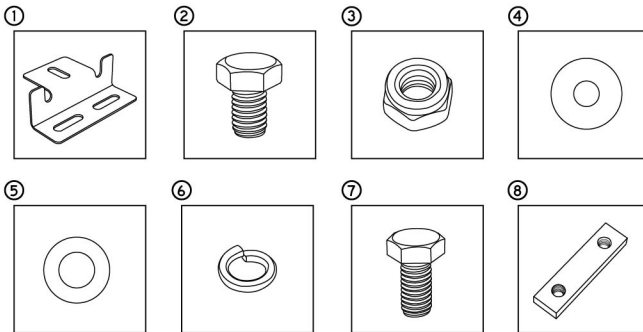

INSTALLATION

NOTE: This installation method uses the XTM Solar Panel Brackets(Sold separately).

1. Align the mounting bracket **1** with the solar panels holes.

2. Put a fender washer **4** and spring washer **6** on the short bolt **2**, then through the mounting bracket and the solar panel, finally a lock nut **3**.

3. Tighten, making sure the mounting bracket supports are pressed firmly against the outside of the solar panel.

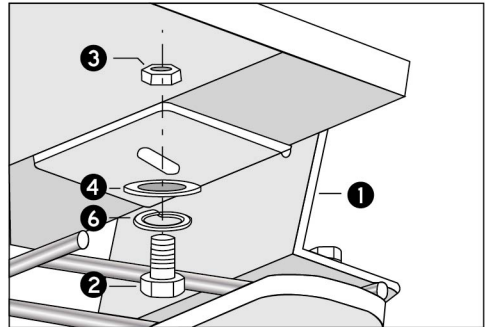

4. Repeat 1 to 3 for each of the four mounting bracket.

5. With all four brackets installed, position the solar panel onto your roof rack.

6. Line up the mounting bracket **1** with thread brace plate **8**, ensuring that there is at least 2 parallel wires running between the bolts.

7. Put a spring washer **6**, then a flat washer **5** onto the long bolt **7** then screw in into the threaded brace plate **8**.

8. Repeat this to secure the solar panel at all four points.

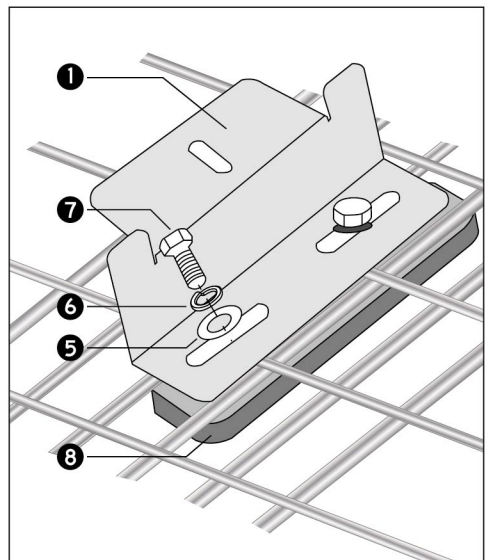

FREQUENTLY ASKED QUESTIONS

Q: Are the fixed solar panels waterproof ?

A: The solar panel is water resistant to a rating of IP65.

Q: Are the fixed solar panel suitable for 6/12/24Volt batteries?

A: No, the fixed solar panels are only for 12Volt batteries.

Q: Can the fixed solar panels be left on the battery permanently?

A: It is recommended that the fixed solar panels are checked regularly as leaving a battery on charge permanently may cause damage to your battery.

WARRANTY

Our product is guaranteed to be free from quality and manufacturing defects for a period of 12 months.

If your product becomes defective during this period, SRGS PTY LTD will offer you either a replacement, credit or refund where a product is faulty; wrongly described; different from the sample shown to you or do not do what they are supposed to do.

This warranty will not cover substantially modified product; misuse or abuse of the product contrary to user instructions or packaging label; change of mind and normal wear and tear.

Our goods come with guarantees that cannot be excluded under the Australian Consumer Law. You are entitled to a replacement or refund for a major failure and for compensation for any other reasonably foreseeable loss or damage. You are also entitled to have the goods repaired or replaced if the goods fail to be of acceptable quality and failure does not amount to a major failure.

To claim the warranty, take the product to the front Service Desk of your nearest store of purchase. You will need to show receipt or other proof of purchase. Additional information may be required to process your claim. Should you not be able to provide proof of purchase with a receipt or bank statement, identification showing name, address and signature may be required to process your claim.

Any expenses relating to the return of your product to the store will normally have to be paid by you. For online store purchases, SRGS PTY LTD will pay for the return freight for any product assessed as having a major failure.

The benefits to the customer given by this warranty are in addition to other rights and remedies of the Australian Consumer Law in relation to the goods or services to which this warranty relates.

This warranty is provided by SRGS PTY LTD, 6 Coulthards Avenue, Strathpine QLD 4500, Australia. Phone: 1300 880 764.



PLU	690243
Construction	Monocrystalline solar panel
Max power (Nom.)	120W
Dimensions	1070x580x17mm
Max power voltage	21.5V
Max power current	5.59A
Open circuit voltage	24.1V
Short circuit current	6A
Power Tolerance	±3%
Cable length	90CM
Operating temperature	-40°C to +85°C
Standard test conditions	AM1.5 1000W/m ² 25°C
Manufactured in	China



PLU: 690243 CODE: 120WFIXED

Manufactured & packaged for

SRGS PTY LTD

ABN 23 113 230 050

6 Coulthards Avenue Strathpine QLD 4500, Australia

MADE IN CHINA