



+ DRIVING LIGHT WITH DRL PHAETHON 224

Instruction Manual

To ensure correct operation, please carefully read the manual before installation.

WARNING: Installation by a licensed auto electrician is recommended.



PLU: 675754
CODE: OL9099
Manufactured and packaged for
SRGS PTY LTD
ABN 23 113 230 050
6 Coulthards Avenue,
Strathpine QLD 4500, Australia
MADE IN CHINA

+ PRODUCT DIMENSION

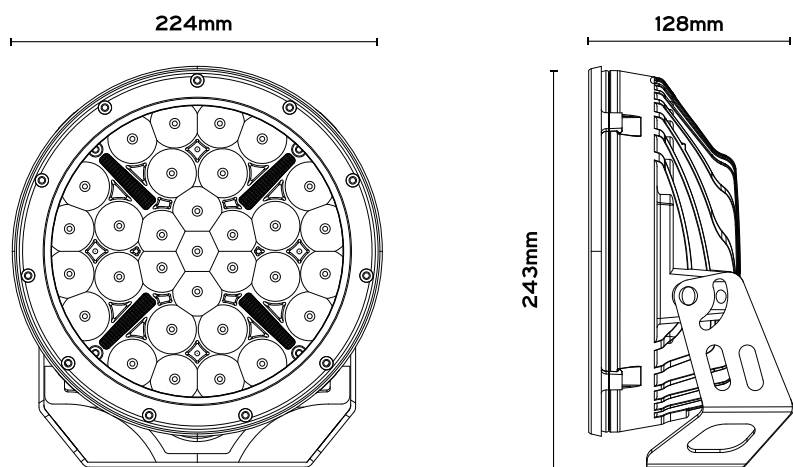

+ KIT CONTENTS

- 2 x 224mm LED driving lights
- 2 x Fitted mounting brackets
- 2 x Lens cover
- 1 x Wiring harness
- 2 x Mounting hardware packs
- 1 x User manual

+ SPECIFICATION

Lumens:	22,000LMS per pair
LED (main light):	31x5W Osram LED with spot beam
DRL:	"X" shape, 4 x 1.5W LED
Beam Length:	1 LUX @ 1,249M per pair
Operating Voltage:	DC 12V - 24V
Current Draw (main light):	11.25A @ 12V/5.65A @ 24V (per light)
Current Draw (DRL):	0.2A @ 12V / 0.08 @ 24V (per light)
Colour Temperature:	6,000K
Waterproof rating:	IP68
Housing:	Dia-cast aluminium alloy
Lens and Lens Cover:	Polycarbonate

+ INSTALLATION

1. Firstly, verify all the components and accessories are included in the package.
2. Test lights to ensure operation before installation. (Red and White cable is positive, and the black is negative.)
3. Bottom bracket mounting way
 - 1) Fitting the small black spacer between the left & right sides of the light and inside the bracket. Insert the hexagon socket bolts with spring and flat washers on each side. Tighten all until the light holds position.
 - 2) Pass the cup-head bolts through the bracket, shockproof pad and mounting holes on the vehicle. Then place the flat washer and nut on the bolt and tighten just enough to allow for final adjustments.

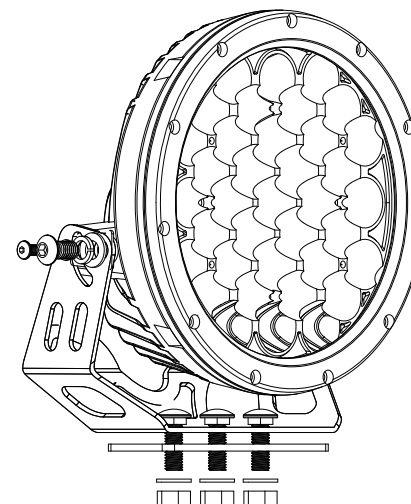

4. Connect the power line to the corresponding power connector. Ensuring polarity is correct (The lights will not operate if the polarity is reversed).
5. Finally, make sure the connections are correct and the brackets are firm yet loose enough for final adjustments. Turn the lights on and check operation.
6. When the lights are operating, aim the light to the position you require it. When the correct position is obtained, tighten all socket screws and bolts, so they are firm and will not move.

* Government legislations may include restrictions on the fitting of vehicle lighting, please ensure you check your local requirements before fitting lights.

+ WIRING HARNESS FITTING INSTRUCTION

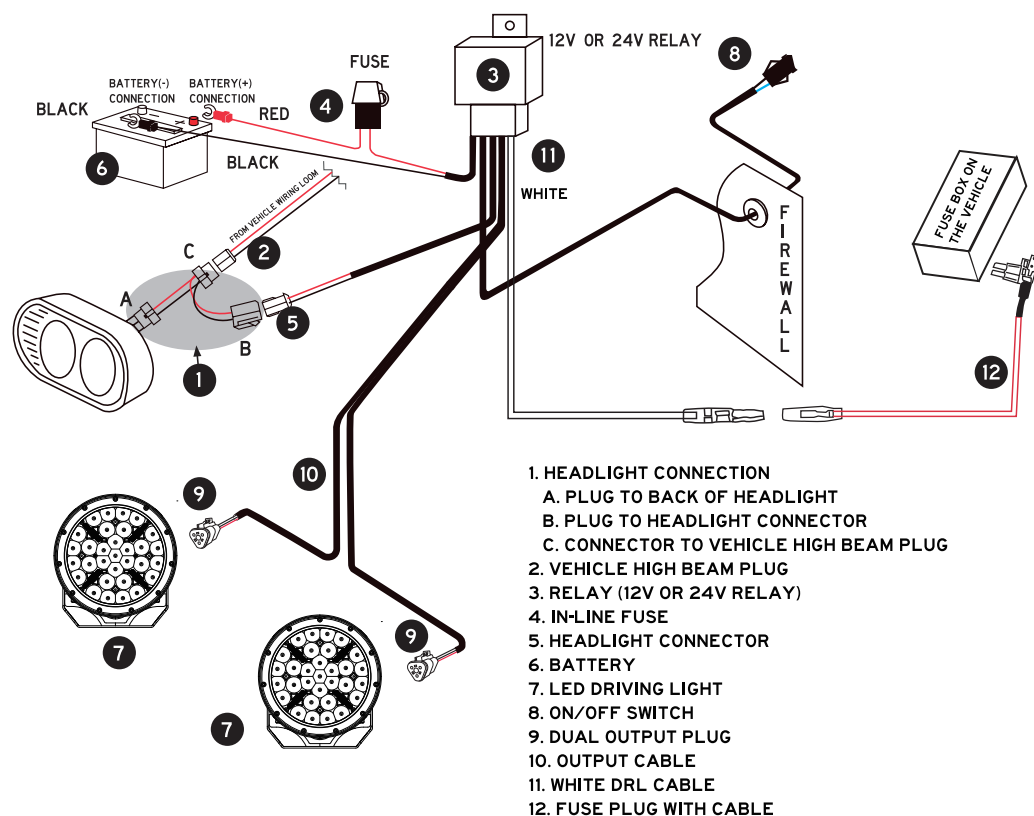

HB3 AND H4 HEADLIGHT CONNECTOR

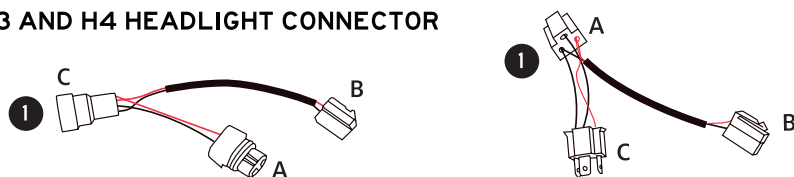

Please Read These Instructions Before Use

Always disconnect the negative battery lead before commencing any electrical work, to ensure personal and vehicle safety.

WARNING: This may result in loss of radio security code and clock settings. Please consult your owner's manual before disconnecting.

SRGS recommends this product to be installed by a qualified auto electrician. SRGS will not be held responsible for any loss or damage arising from the improper installation of this product.

The wiring harness is designed as a simple plug and connect loom to install driving lights to most conventional wiring circuits.

Installation:

1. Familiarize yourself with the connections by laying out the wiring loom and inspecting. Take note of the cable and location for the following:

- ON/OFF switch, which is to be mounted inside of the cabin. (picture 8)
- White plug to be connected to the vehicle's headlights. (picture 5)
- Dual output plugs to be connected to your driving light. (picture 9)
- HB3 and H4 headlight connector. (picture 1)

2. Lay out the wiring in the engine bay, making sure the plugs can reach the location of your lights, the terminals can reach the battery and the switch can penetrate through the firewall.

3. Connect relay harness connector to the relay (12V or 24V).

4. Take the in-line fuse out of the wiring harness.

5. Connect the negative(-) wire to the negative terminal of the battery.

6. From the relay there is length of cable with a single white plug on the end. This is to connect your headlight to your high-beam switch. Run this wire to the back of the headlight, disconnect the plug and place the appropriate headlight adapter in-line. Connect the adapter to your driving light harness.

7. Next, run the wire with dual output plug to the front of your vehicle, and connect them to the driving lights.

8. White DRL cable connection (picture 11)

(1) Applicable to vehicle with original DRL.

Connect the white wire to vehicle DRL circuit (+).

(2) Applicable to vehicle without original DRL.

Replace an accessory fuse in the fuse box with the correct size fuse plug, and connect the fuse wire terminal to the white DRL cable terminal. (picture 12)

Ensure there is a drip loop to stop water ingress and seal with a suitable sealant.

9. Then, disconnect the terminals from the switch and run them through the firewall into your vehicle's cabin. Find a suitable location to mount the switch and reconnect the terminals.
 10. Connect the positive(+) wire to positive(+) battery terminal and insert the in-line fuse back into its socket.
 11. Double check all of your connections and ensure that all cables are routed and secured in a safe manner, not rubbing on sharp surfaces or pinched by moving components.
 12. Check that driving lights operate correctly. The main light of driving lights will only light up when high beam is used and ON/OFF switch is in the "ON" position.
- For 24V DC applications, change the relay to a 24V DC standard relay.

+ WARRANTY

Our product is guaranteed to be free from quality and manufacturing defects for a period of 12 months.

If your product becomes defective during this period, SRGS PTY LTD will offer you either a replacement, credit or refund where a product is faulty; wrongly described; different from the sample shown to you or do not do what they are supposed to do.

This warranty will not cover substantially modified product; misuse or abuse of the product contrary to user instructions or packaging label; change of mind and normal wear and tear.

Our goods come with guarantees that cannot be excluded under the Australian Consumer Law. You are entitled to a replacement or refund for a major failure and for compensation for any other reasonably foreseeable loss or damage. You are also entitled to have the goods repaired or replaced if the goods fail to be of acceptable quality and failure does not amount to a major failure.

To claim the warranty, take the product to the front Service Desk of your nearest store of purchase. You will need to show receipt or other proof of purchase. Additional information may be required to process your claim. Should you not be able to provide proof of purchase with a receipt or bank statement, identification showing name, address and signature may be required to process your claim.

Any expenses relating to the return of your product to the store will normally have to be paid by you. For online store purchases, SRGS PTY LTD will pay for the return freight for any product assessed as having a major failure.

The benefits to the customer given by this warranty are in addition to other rights and remedies of the Australian Consumer Law in relation to the goods or services to which this warranty relates.

This warranty is provided by SRGS PTY LTD, 6 Coulthards Avenue, Strathpine QLD 4500, Australia. Phone: 1300 175 010.