

**4x4 ACCESSORIES**

# + XTM ROOF TRACK GUTTER MOUNT KIT

## Owner's Manual

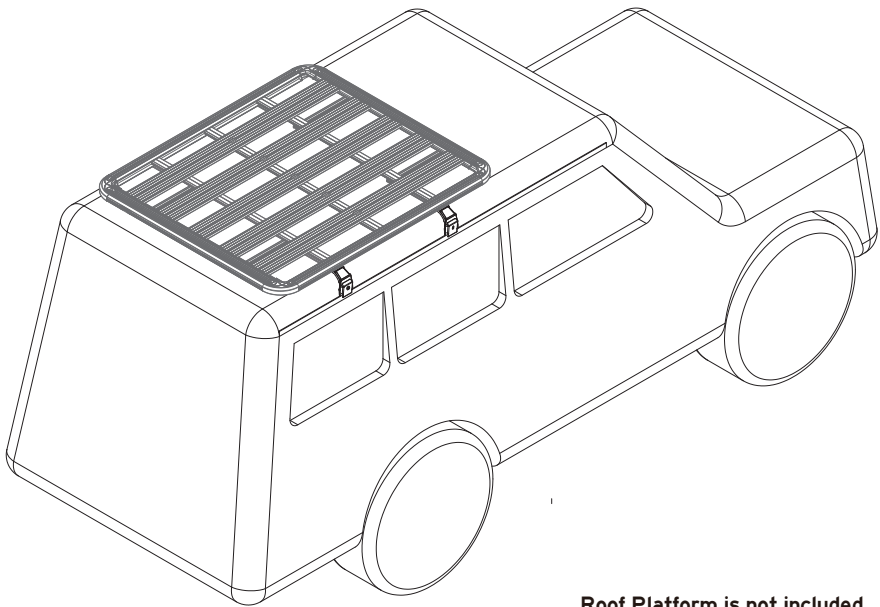







210MM

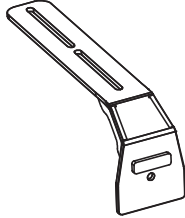

**Roof Platform is not included.**

148MM

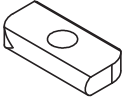
## + PARTS LIST

<b>Bracket A</b> <b>4 PCS</b> 	<b>Bracket B</b> <b>4 PCS</b> 
<b>M5 Hex key</b> <b>1 PCS</b> 	<b>M8X25MM Bolt</b> <b>8 PCS</b> 
<b>M8 Spring washers</b> <b>12 PCS</b> 	<b>M8 Washers</b> <b>12 PCS</b> 
<b>M8 Square bolt</b> <b>8 PCS</b> 	<b>M8X30MM Bolt</b> <b>4 PCS</b> 

## + WARNING

Please read and understand all the following safety information prior to installing and using this Gutter Mounts. Check the weight capacity of your vehicle from your vehicle manufacturer before installation of this Gutter Mounts Set.

- +This Gutter Mounts is designed to fit XTM ROOF PLATFORM only. Do not use for any other purpose or any other model of ROOF PLATFORM.
- +The loading capacity of this Gutter Mounts is 200KGS in static conditions. DO NOT overload.
- +Ensure that all the mounting brackets are installed correctly as per instructions. Inspect the connections periodically to ensure all bolts and nuts are tight.

## + MOUNTING KIT ASSEMBLY

### STEP: 1

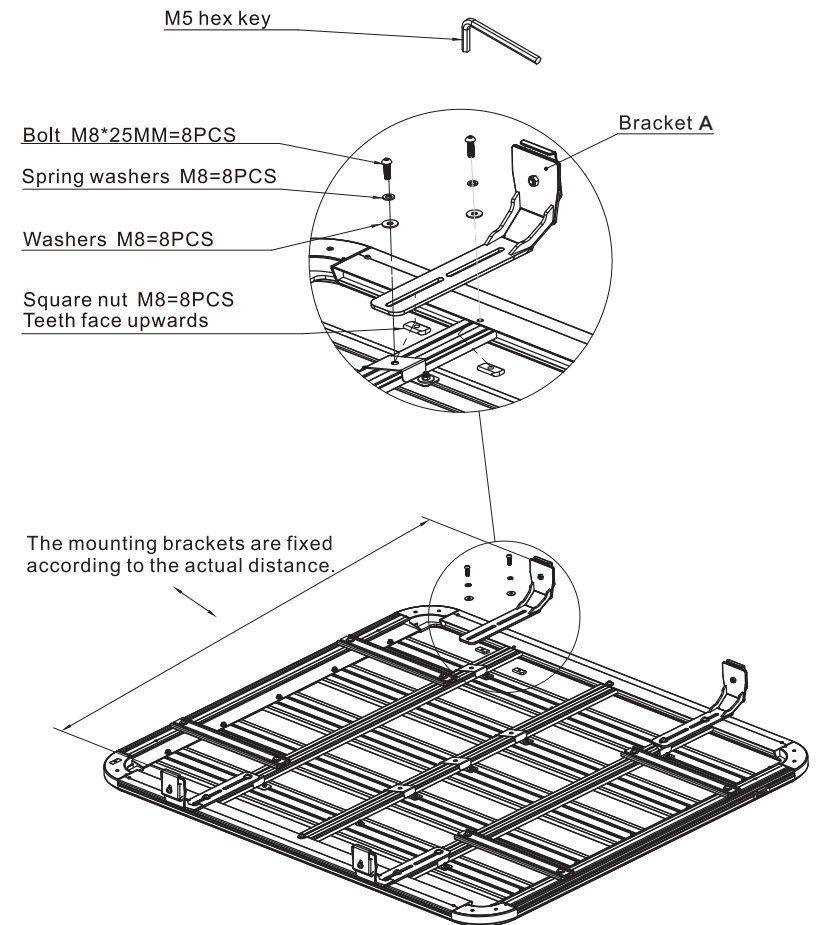

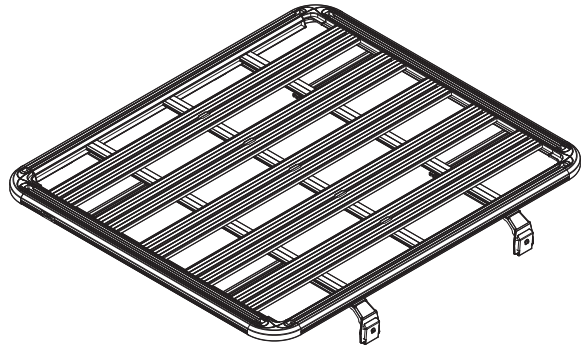

## STEP: 2

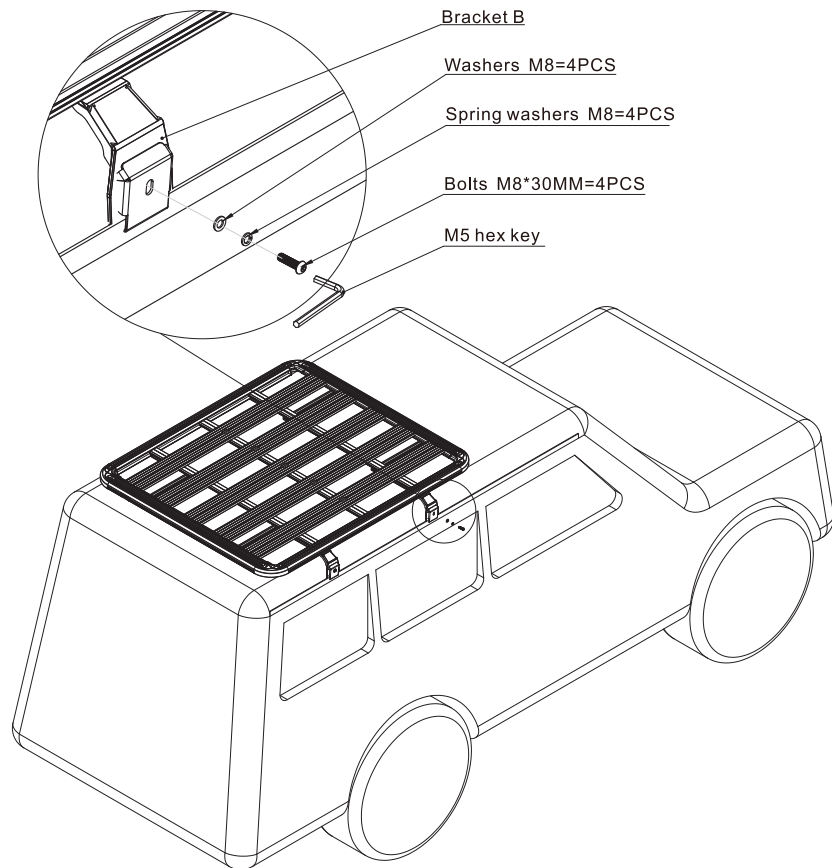

## + WARRANTY

Our product is guaranteed to be free from quality and manufacturing defects for a period of 12 months. If your product becomes defective during this period, SRGS PTY LTD will offer you either a replacement, credit or refund where a product is faulty; wrongly described; different from the sample shown to you or do not do what they are supposed to do.

This warranty will not cover substantially modified product; misuse or abuse of the product contrary to user instructions or packaging label; change of mind and normal wear and tear.

Our goods come with guarantees that cannot be excluded under the Australian Consumer Law. You are entitled to a replacement or refund for a major failure and for compensation for any other reasonably foreseeable loss or damage. You are also entitled to have the goods repaired or replaced if the goods fail to be of acceptable quality and failure does not amount to a major failure.

To claim the warranty, take the product to the front Service Desk of your nearest store of purchase. You will need to show receipt or other proof of purchase. Additional information may be required to process your claim. Should you not be able to provide proof of purchase with a receipt or bank statement, identification showing name, address and signature may be required to process your claim.

Any expenses relating to the return of your product to the store will normally have to be paid by you. For online store purchases, SRGS PTY LTD will pay for the return freight for any product assessed as having a major failure.

The benefits to the customer given by this warranty are in addition to other rights and remedies of the Australian Consumer Law in relation to the goods or services to which this warranty relates.

This warranty is provided by SRGS PTY LTD, 6 Coulthards Avenue, Strathpine QLD 4500, Australia.  
Phone: 1300 880 764.

PLU: 669709 CODE: CZ-MT01A  
Manufactured and packaged for  
SRGS PTY LTD  
ABN 23 113 230 050  
6 Coulthards Avenue  
Strathpine QLD 4500, Australia  
MADE IN CHINA