

4x4 ACCESSORIES

+ XTM ROOF PLATFORM

Instruction Manual

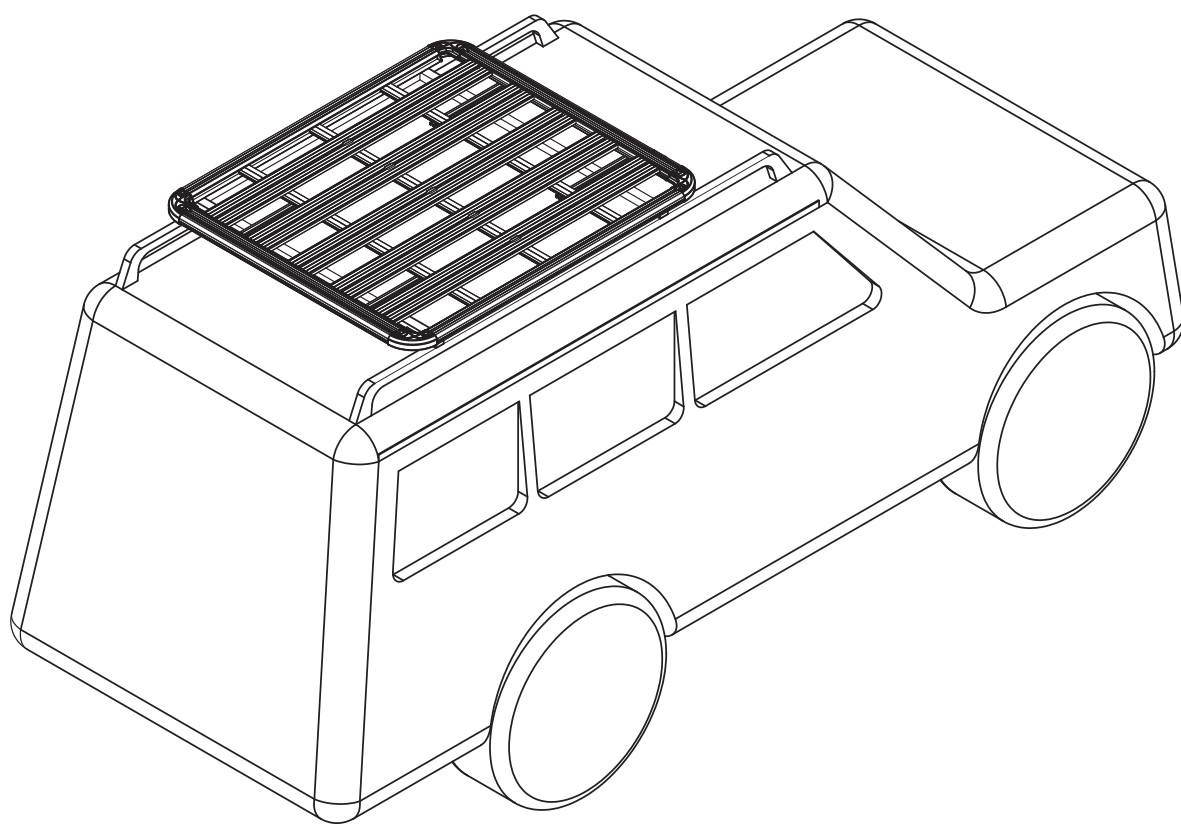

PLU: 669707

Thank you for purchasing the XTM Roof Platform. Please read these instructions carefully before assembling and installing the Roof Platform to your vehicle. Assembly and installation requires minimum 2 people.

Tools required (not included):

- Rubber hammer
- Cross screwdriver
- 10mm Spanners

Note: SRG accepts no responsibility for incorrect fitment / accidental damage to vehicle during fitment. If unsure, please contact a reputable accessory fitter to install the roof platform for you.

IMPORTANT







Load and weight capacities of the roof platform is dependent on vehicle load ratings. Please be aware of vehicle load ratings before use.





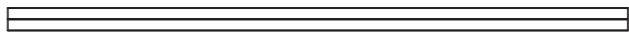



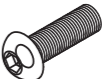

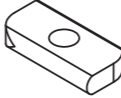

Before installing the roof platform please ensure you are aware and understand the following:

- Your vehicle's maximum load rating.
- Your vehicle's maximum load rating including off-road capacity.

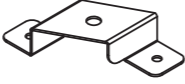
Note: Roof platform off-road limits are different to normal road use load ratings. If in doubt contact your vehicle manufacturer for the specific loading capacity of your vehicle.

+ Parts list

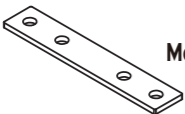
A		2 pcs
B		2 pcs
C		2 pcs L 2 pcs R
D		3 pcs
E		5 pcs
F		4 pcs
G		Self-tapping screw 4.2*20 8 pcs
H		M5 Hex key 1 pcs
I		Bolt M8*25MM 6 pcs

J	 M8 Spring washers 14 pcs	K	 Bolt M6*15MM 10 pcs
L	 M4 Hex key 1 pcs	M	 M8 Square bolt 18 pcs
N	 M8 Washers 14 pcs	O	 M6 Washers 50 pcs
P	 M6 Nyloc nut 40 pcs	Q	 U bracket 15 pcs
R	 T Bolt M6*16MM 30 pcs	S	 Bolt M8*30MM 8 pcs
T	 M8 Tie down ring 4 pcs	U	 Bolt M8*65MM 8 pcs
V	 Mounting plate 4 pcs	W	 M8 Nyloc nut 8 pcs

+ Assembly

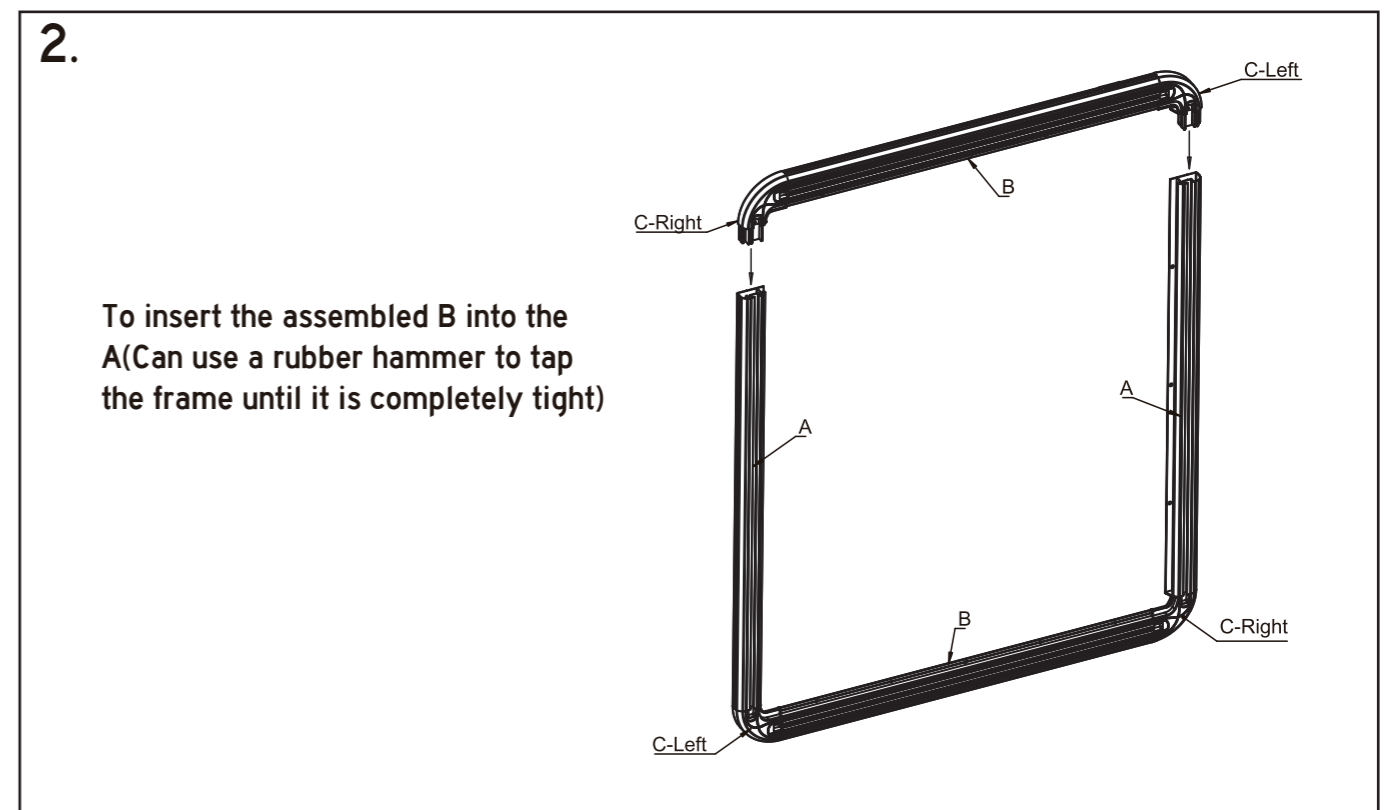
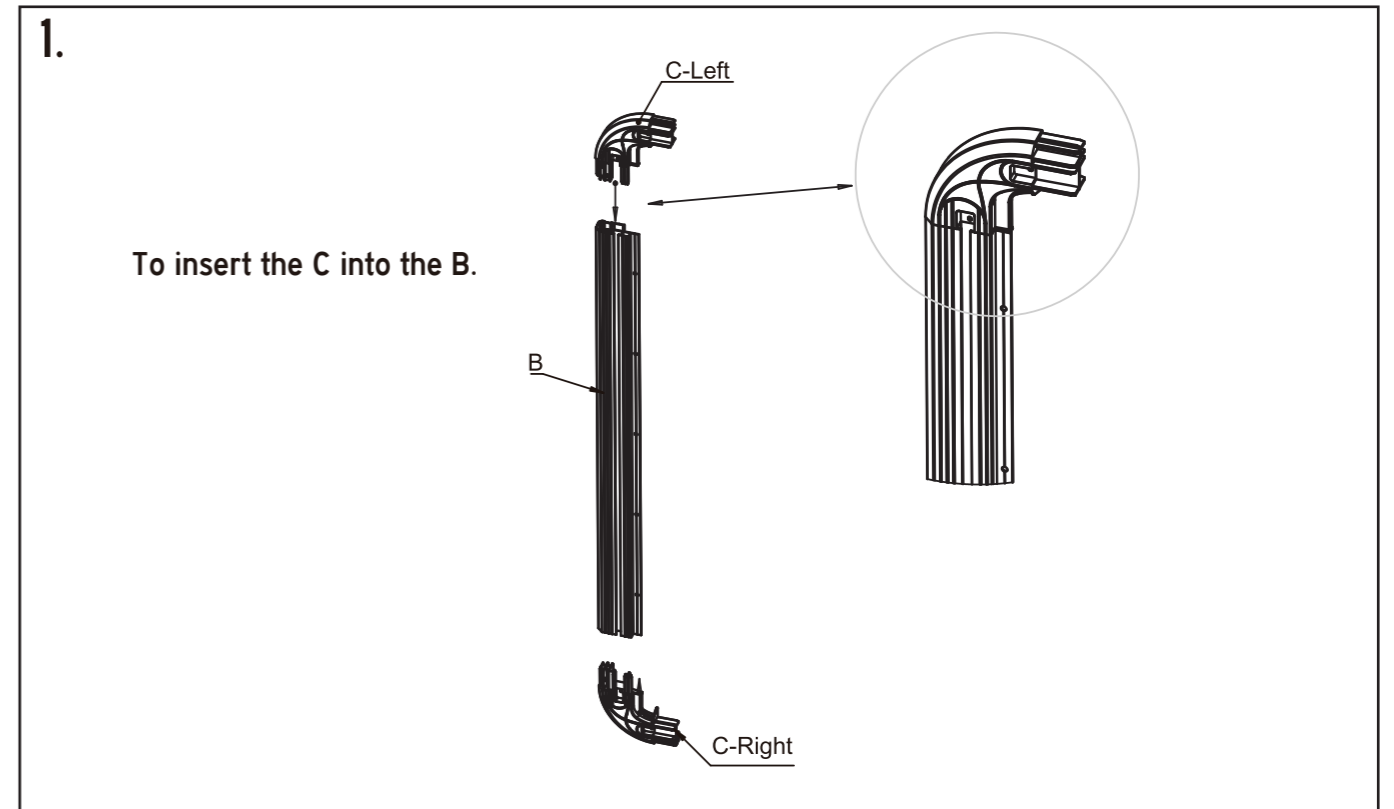

3.

Place the assembled unit flat and tighten the Self-tapping screw using your own screwdriver.

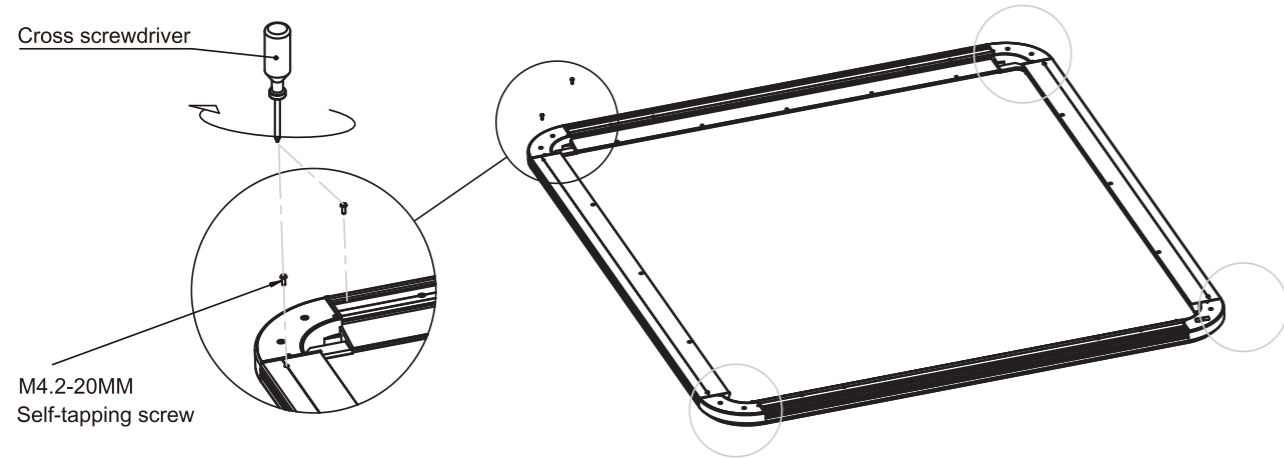

4.

Position D inline with holes on A as shown below.

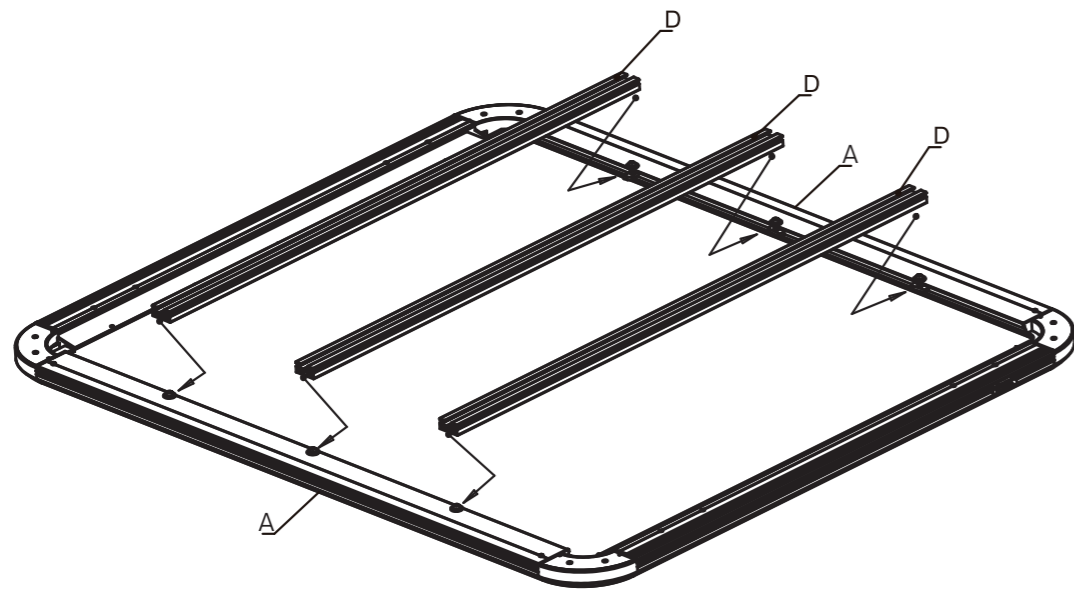

5.

Slide the M8 square nut (teeth face up) into the slot of the D, then tighten the bolts with spring washer and washer using the M5 Hex key provided.

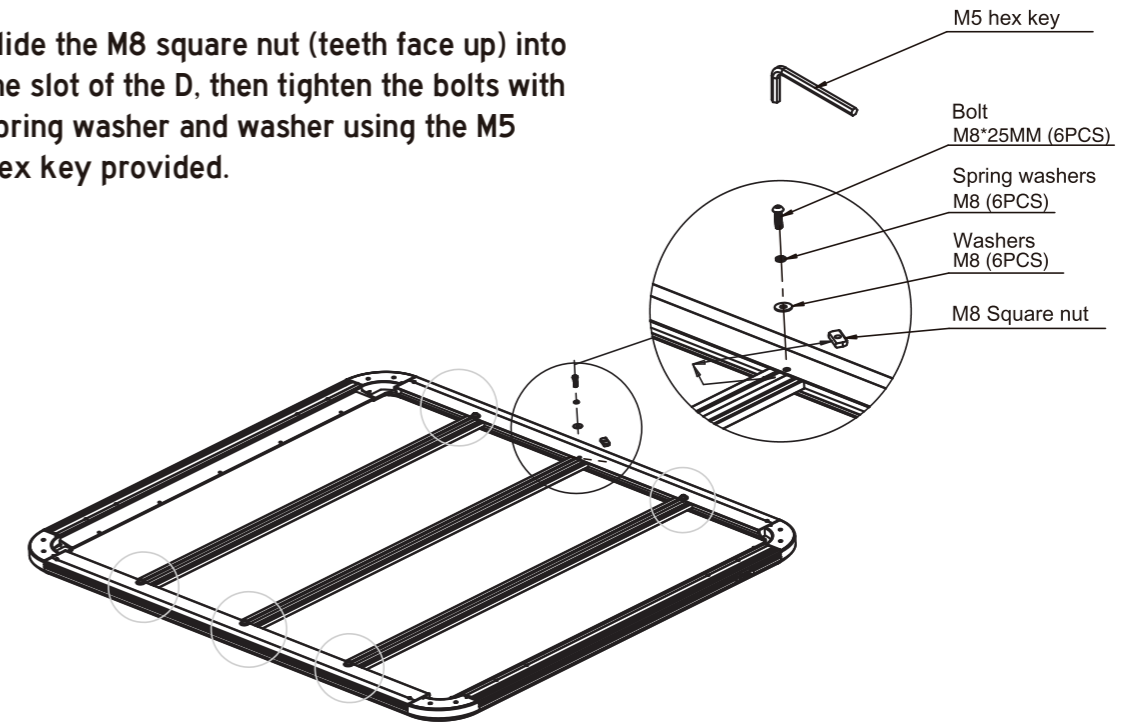

6.

Align the holes at both ends of the E with the holes in the frame, and tighten the bolts with washers and nyloc nut using the M4 Hex key provided. (Suggest to fasten the nyloc nuts with an open-end spanner before tightening for easier process)

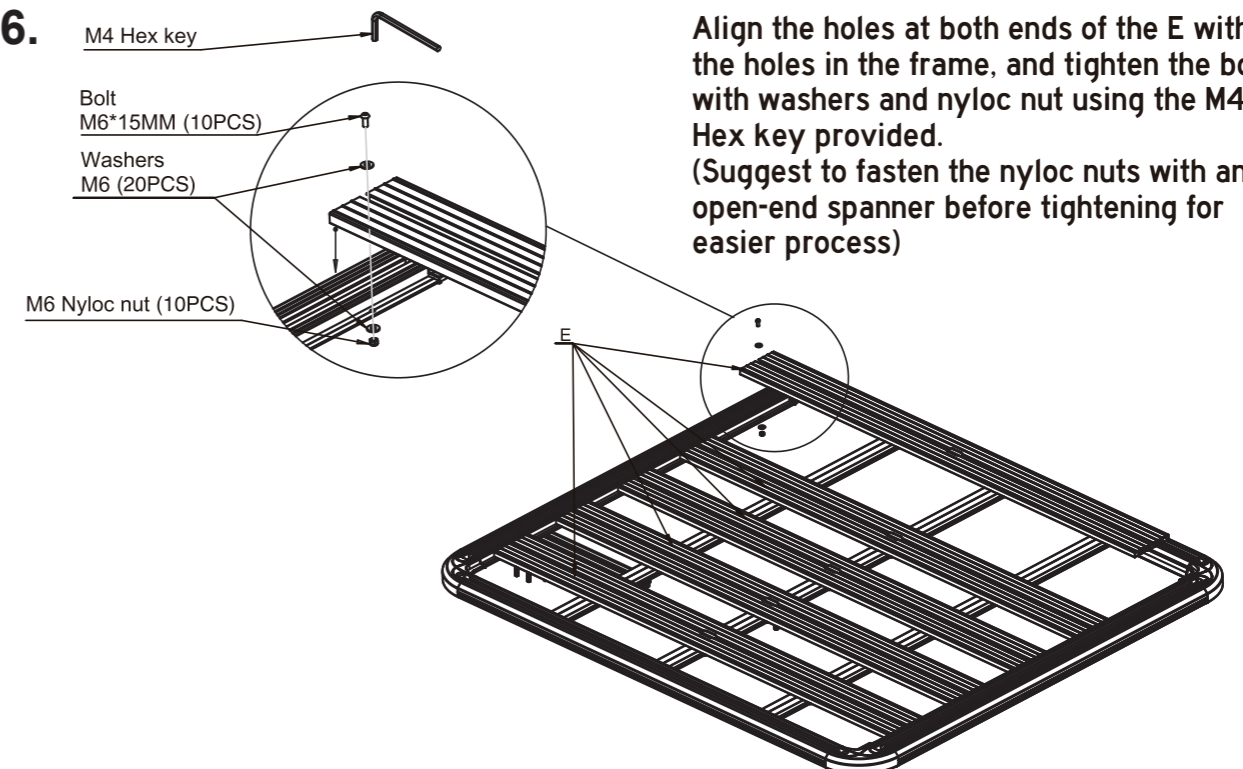

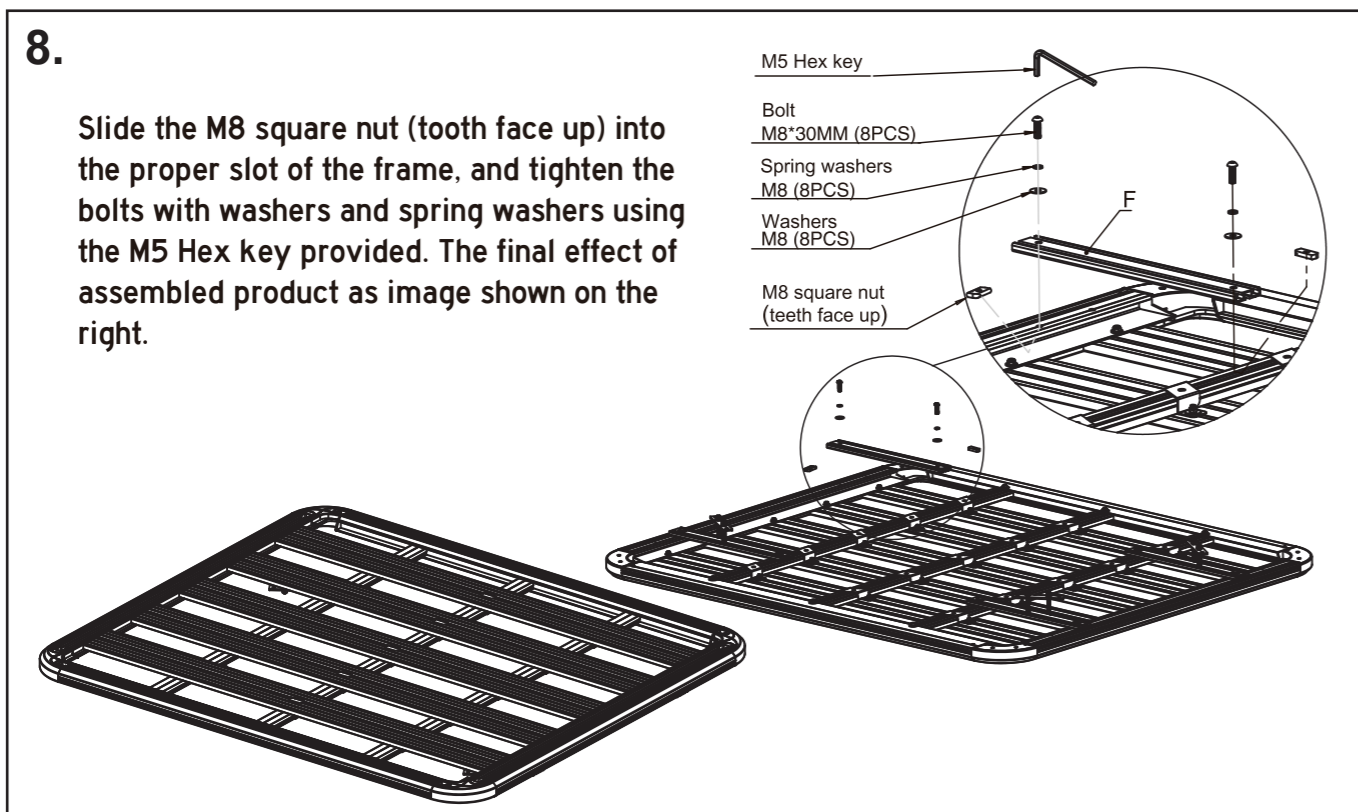
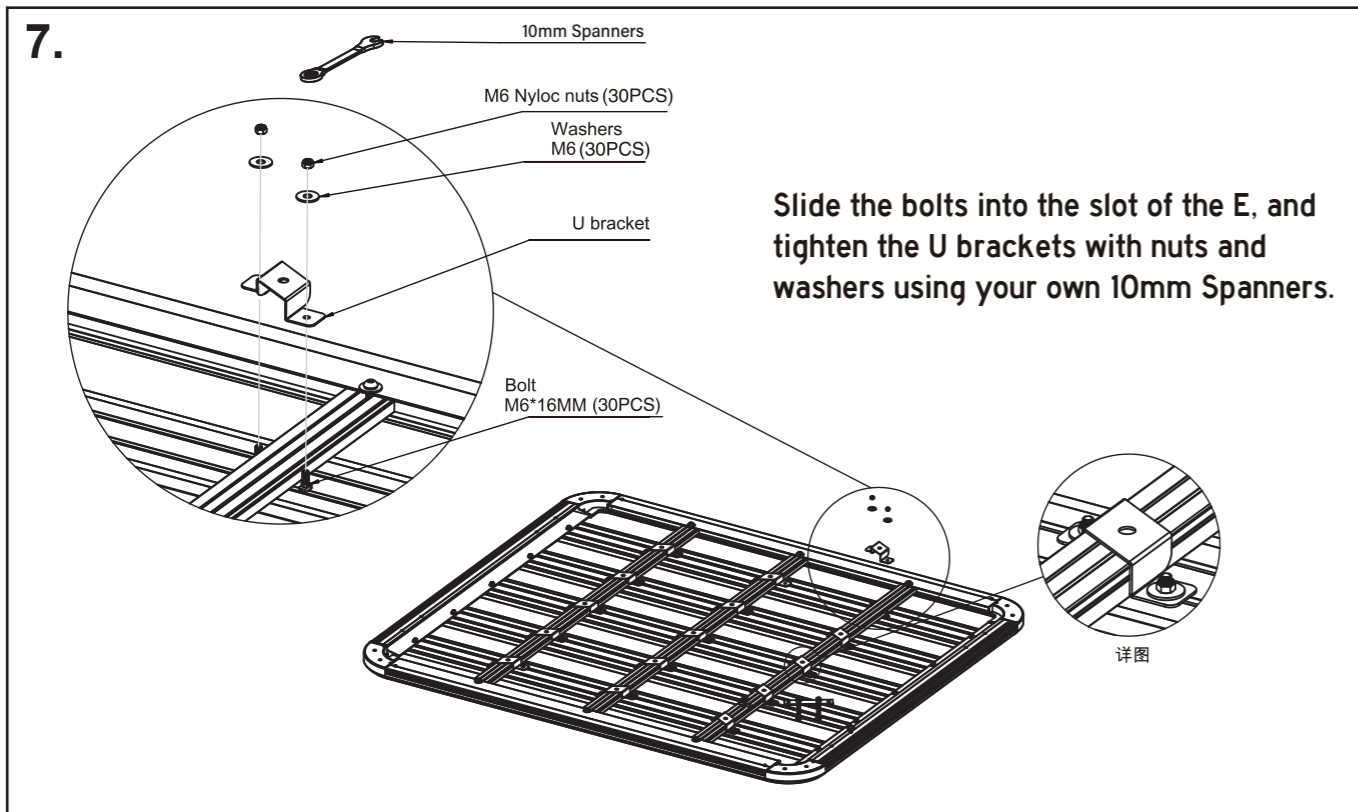

+ Mounting

Pull out the end caps before sliding the bolts into the slot of F, and tighten the mounting plates with nuts.

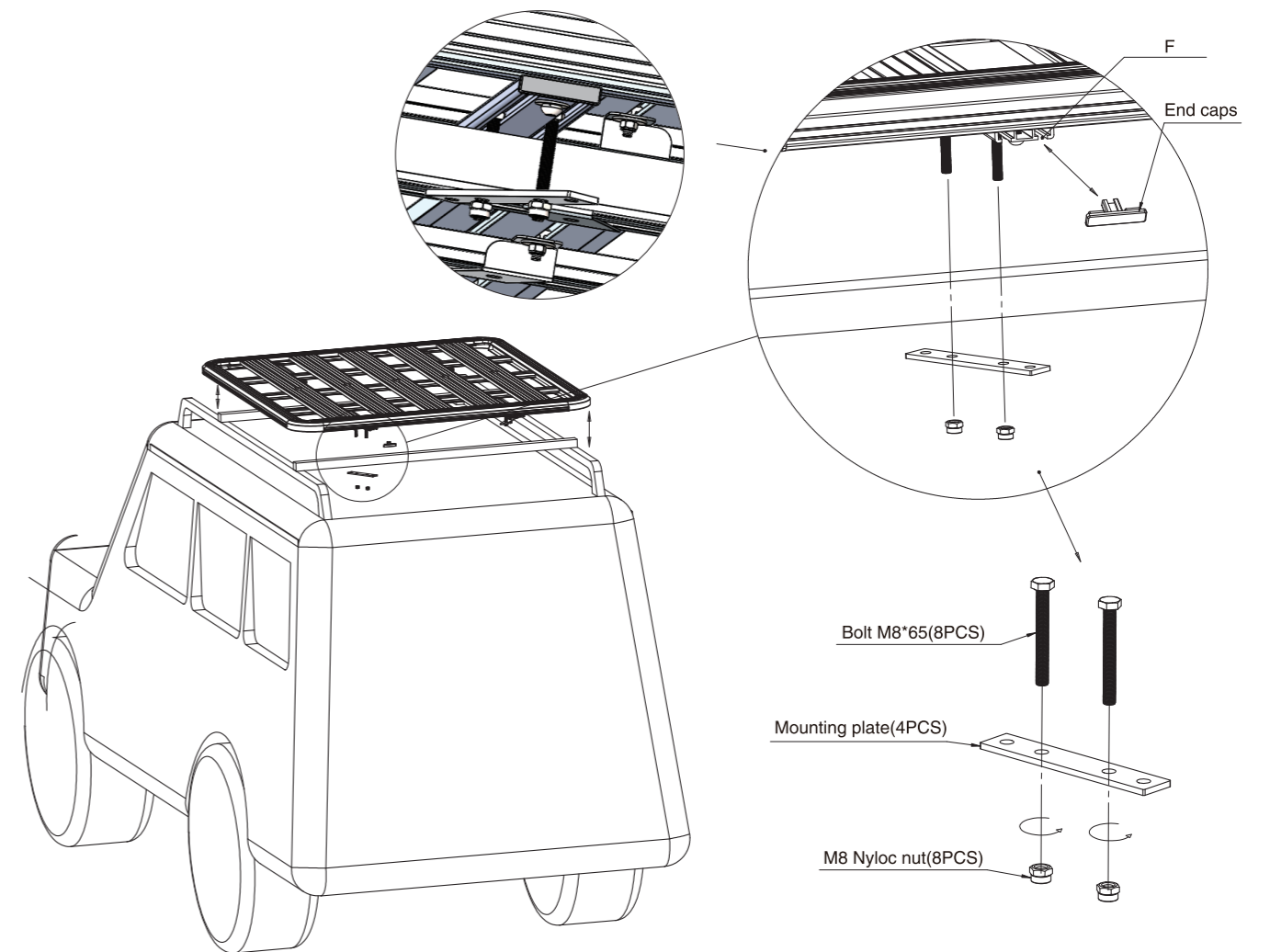

PLU: 669707 CODE: CZ-RT04B
Manufactured and packaged for
SRGS PTY LTD
ABN 23 113 230 050
6 Coulthards Avenue
Strathpine QLD 4500, Australia
MADE IN CHINA