



RHINO-RACK

43173 - Pioneer Platform/ Tradie LED Light Bracket
Does not fit Pioneer Welded Tray.

Place these instructions in the vehicle's glove box after installation is complete.

Important: Please read these instructions carefully prior to installation.
 Please refer to your fitting instruction to ensure that the alloy tray is installed correctly.
 Check the contents of this kit before commencing fitment and report any discrepancies.

Item	Component Name (Dual Bracket Kit)	Qty	Part No.
1	RH LED Light Bracket	1	CA1436
2	LH LED Light Bracket	1	CA1435
3	M8 x 20 Button Cap Screw	4	B155
4	M8 Spring Washer	4	W019
5	M8 Flat Washer	4	W020
6	M8 Channel Nut	2	N003
7	Security Allen Key 5mm	1	H021
8	M8 Tooth Grip Washer	2	W033
9	M6 x 20 Socket Head Screw	2	B054
10	M6 Spring Washer	2	W004
11	M6 x 16 x 1.6 Flat Washer	2	W031
12	M6 Shake Proof Washer	2	W056
13	Fitting Instructions	1	R718

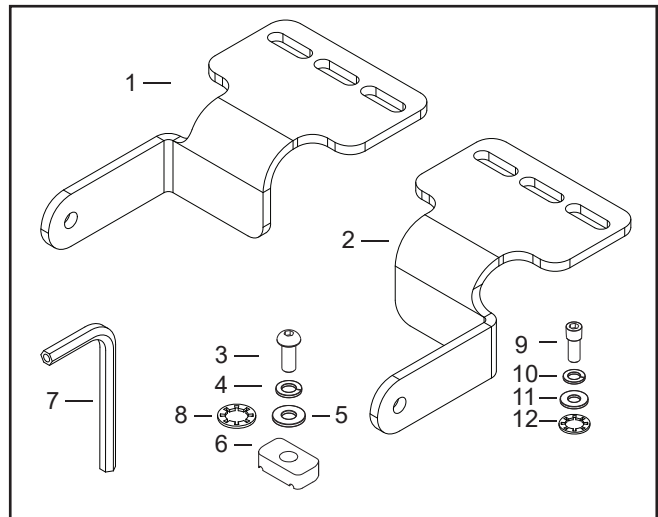

1 Measure the length of your Light Bar to determine what tray planks will be used in the install of the brackets. **Refer to pg 2 for all possible fit sizes.**

(x)

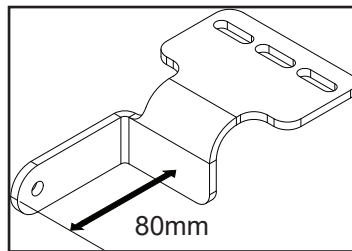
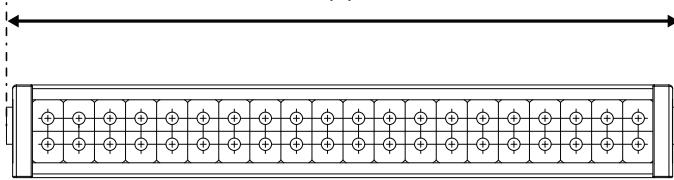

Front View:

2 Attach the Brackets onto the Platform by first sliding an M8 Channel nut into the 'C' channel of the Platform. Place the bracket over this and fix in place with an M8 Button Head Screw, M8 Spring and Flat Washer.

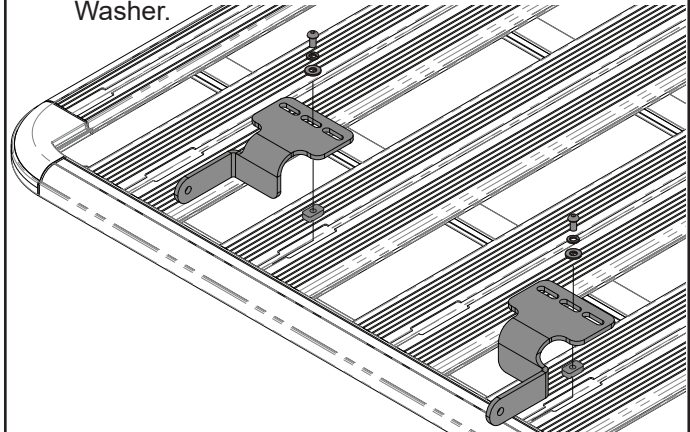

3 Determine whether your Light Bar requires M6 or M8 hardware.
 For an M8 setup use items : 3,4,5 and 8 as shown.
 For an M6 setup use items: 9,10,11 and 12 as shown.

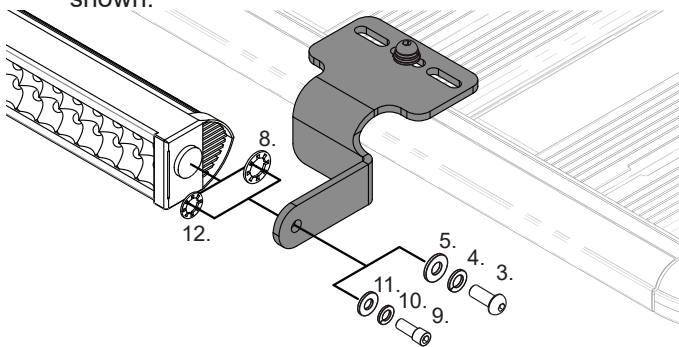

4 Fix the Light Bar to the Brackets using the hardware supplied within the Light Bar Kit purchased.

Note: Light Brackets can be fitted to every side of the Pioneer Platform or Tradie Tray. On the Pioneer Tray light brackets can only fit the rear and sides.

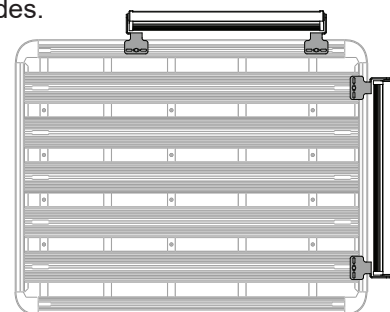

Top View:



43173 - Pioneer Platform/ Tradie LED Light Bracket
Does not fit Pioneer Welded Tray.

Note:

4 series - Be aware of the maximum and minimum spacing possible for the LED Light Bracket. Note that to achieve a minimum spacing Left and Right Bracket positions are reversed.

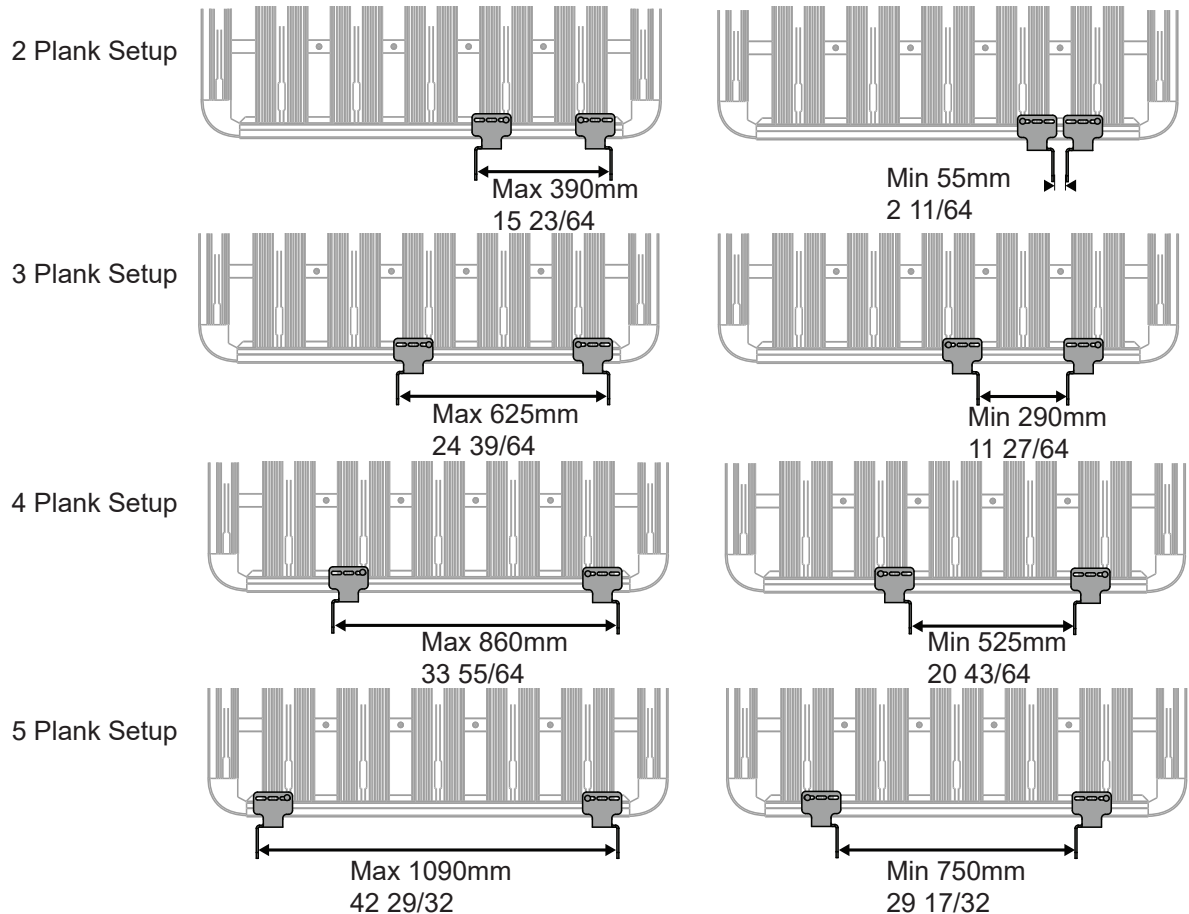

Note:

For heavy/ long LED light bars: It is possible that the LED light installed may move up or down in off-road conditions. To prevent this, locate a suitable spot on your LED light bar that can serve as a locking position, drill through the bracket and connect the two points with suitable hardware. Note that variations in LED light bars will alter this step slightly. (Hardware not supplied in this kit)

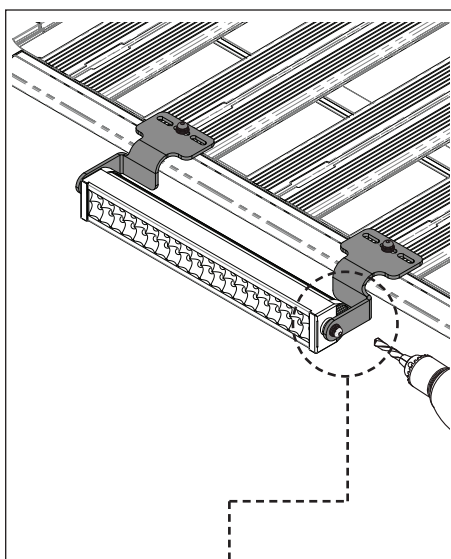

Locate a suitable position for drilling. Look to have the hole in the bracket line up with a position on the light bar that will provide purchase for any hardware used.

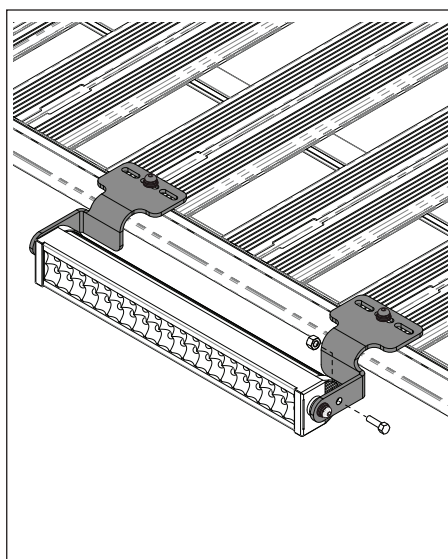

Select the appropriate hardware and fix the light bar in position.

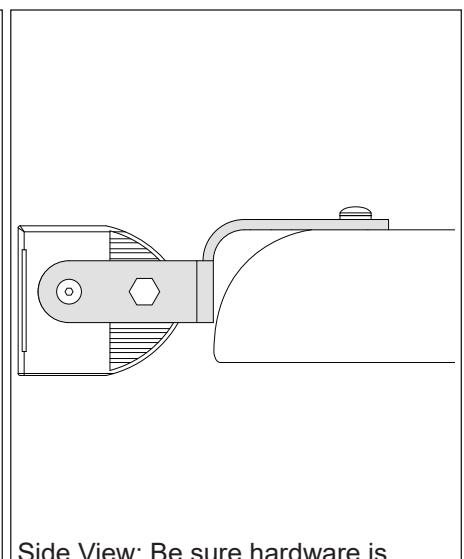

Side View: Be sure hardware is secure before use.
Note: Apply Cold Galvanizing Paint on the drilled area to prevent corrosion.



43173 - Pioneer Platform/ Tradie LED Light Bracket
Does not fit Pioneer Welded Tray.

Note:

The 43173 LED Brackets can be fitted to the underside of a Pioneer Tray as shown. Fix the Bracket to the front or rear Crossbar of the Tray.

Side View:

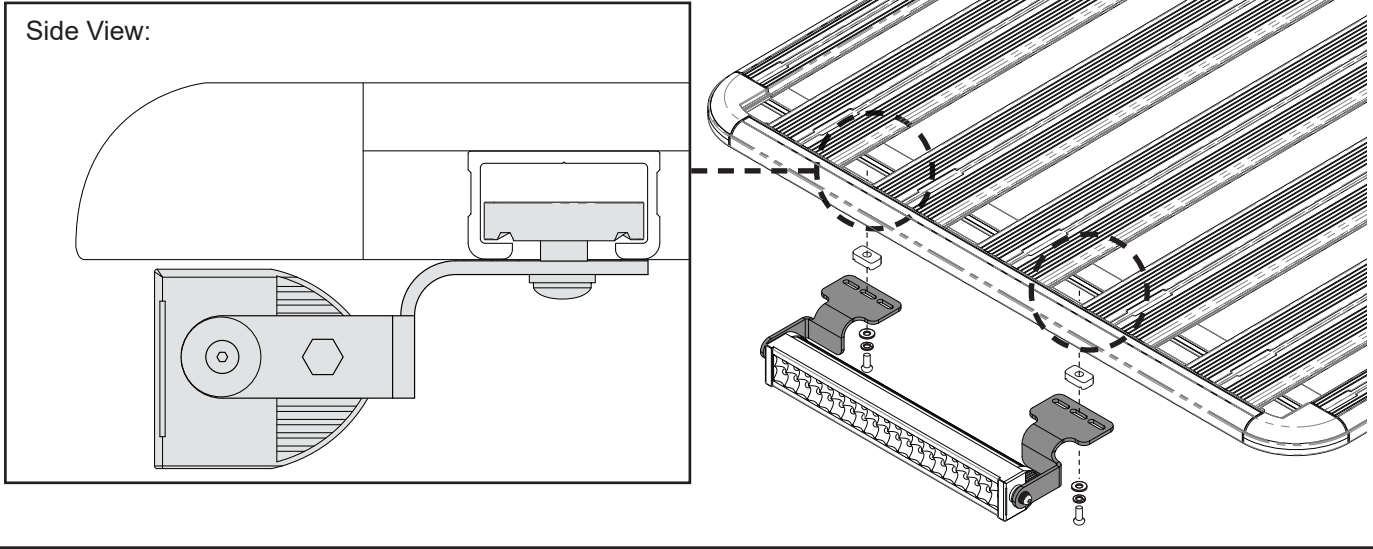

52xxx series platforms fitment information.

		Light Bar Lengths					
Max light bar length (mm)	Max light bar length inches	Compatible platform					
1050	41.3	52100	52102	52107	52109		
1190	46.9	52101	52103	52110			
1240	48.8	52104	52108	52111	52112	52113	52121
1280	50.4	52105					
1400	55.1	52119					
1655	65.1	52120					

**Rhino-Rack, 22A Hanson Pl, Eastern
 Creek NSW 2766, Australia**
 (02) 8846 1900
 rhinorack.com.au

Document No: R718
Issue No: 09
Issue Date: 19/08/2020

Note for fitters and dealers:

It is your responsibility to ensure these instructions are given to the end user or client. Vortex crossbars can be cut to length to fit this vehicle. Measure the desired length out from the centre of the Vortex Bar and create a reference with a marker. Carefully cut the bar at these markings using a Saw with an Alloy Cutting Blade.