

BOOST EVA

GBC013



RUGGED STORAGE. EVA PROTECTIVE CASE.

DESIGNED FOR
NOCO BOOST[®]
ULTRASAFE[®] LITHIUM JUMP STARTERS.

COMPATIBLE WITH:

GB20

GB30

GB40



NOCO[®]

30339 Diamond Parkway, #102
Glenwillow, OH 44139 | USA
1.800.456.6626

no.co

SECURE FIT.

The molded tray interior has a soft black melange velvet lining for a secure fit.

EXTRA POCKETS.

The reinforced semi-rigid pockets securely hold clamps, extensions or other accessories.



*Boost & Accessories Not Included

RUGGED EVA.

Made of thermoformed EVA, the GBC013's lightweight and durable molded exterior has a water resistant, rubber-like finish.

REINFORCED ZIPPER.

The case is sealed with a heavy-duty reverse coil zipper, a built-in reinforced handle, and custom over-molded pull tabs.



PORTABLE DESIGN.

Store the protective case easily in your trunk, vehicle, console, or garage. The GBC013 offers protection from moisture, impact, dust, and environmental factors.

WHAT'S IN THE BOX

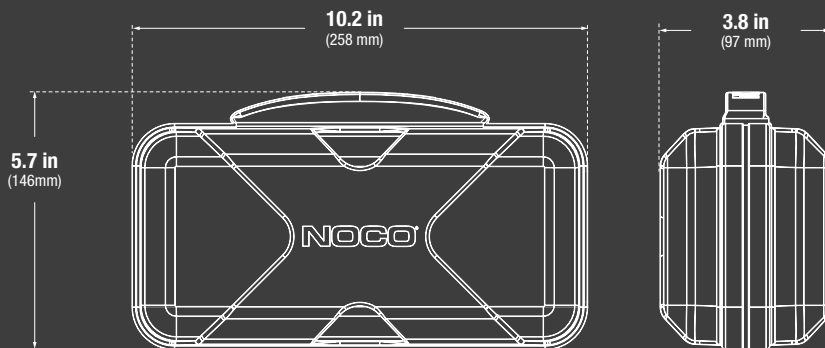

TECHNICAL SPECIFICATIONS

COMPATIBILITY:	GB20,GB30,GB40	
WEIGHT:	0.80 lbs (0.49kg)	
VOLUMETRICS:	Inner Carton: Dimensions: 9.84" x 4.72" x 3.15" Weight: 4.50 lbs UPC: 0-46221-17027-6	Master Carton: Dimensions: 19.49" x 10.63" x 9.06" Weight: 37.57 lbs Quantity: 6 UCC: 10046221170273
	Units Per Pallet: 300 Units	

NOCO

30339 Diamond Parkway, #102
Glenwillow, OH 44139 | USA
1.800.456.6626

no.co